

# Triton Go Product Manual

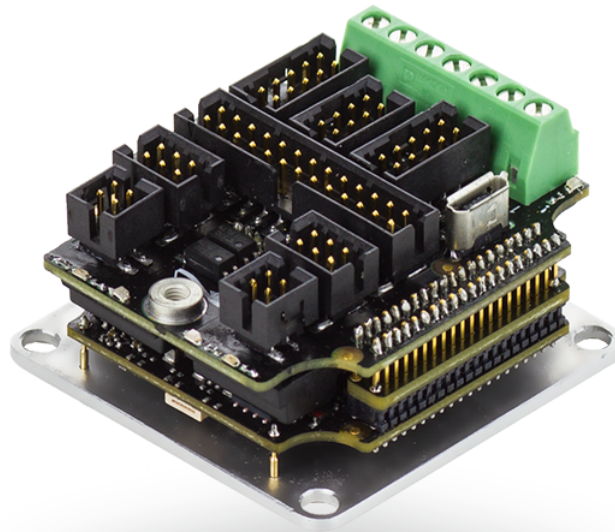

Edition 05/29/2017

*For the most up to date information visit the online manual.*



INGENIA-CAT S.L.  
8-14 MARIE CURIE, ADVANCED INDUSTRY PARK  
08042 BARCELONA

**INGENIA**  
passion for motion

# 1 Table of Contents

<b>1</b>	<b>Table of Contents</b>	<b>2</b>
<b>2</b>	<b>General Information</b>	<b>5</b>
2.1	Manual revision history .....	5
2.2	Disclaimers and limitations of liability .....	5
2.3	Contact .....	5
<b>3</b>	<b>Safety Information</b>	<b>7</b>
3.1	About this manual.....	7
3.2	Warnings.....	7
3.3	Precautions .....	7
<b>4</b>	<b>Product Description</b>	<b>8</b>
4.1	Triton part numbering .....	8
4.2	Specifications.....	10
4.3	Hardware revisions .....	16
4.4	Power and current ratings.....	16
4.4.1	Power losses calculation (heat dissipation) .....	17
4.4.2	Current ratings .....	18
4.4.3	System temperature .....	20
4.4.4	Improving heat dissipation with a heatsink .....	20
4.5	Architecture .....	21
<b>5</b>	<b>Connectors Guide</b>	<b>23</b>
5.1	Supply, shunt and motor connector .....	24
5.2	Milli-Grid connectors mating.....	25
5.3	Halls and motor temperature connector .....	27
5.4	Absolute encoder connector .....	29
5.5	Incremental and Sin-Cos encoder connector.....	31
5.6	USB connector .....	33
5.7	I/O and LEDs connector .....	35
5.8	RS485 interface connector .....	39
5.9	Safe Torque Off (STO) connector .....	41
5.10	EtherCAT connectors (TRI-x/48-E-C) .....	43
5.11	CAN connectors (TRI-x/48-C-C) .....	46
<b>6</b>	<b>Signalling LEDs</b>	<b>48</b>
6.1	Power and operation signalling LEDs .....	48
6.2	CAN signalling LEDs (only TRI-x/48-C-C) .....	49
6.3	EtherCAT signalling LEDs (only TRI-x/48-E-C).....	50
<b>7</b>	<b>Wiring and Connections</b>	<b>52</b>
7.1	Protective earth .....	52
7.2	Power supply.....	55
7.2.1	Power supply requirements .....	55
7.2.2	Power supply connection .....	56
7.2.3	Battery supply connection .....	57
7.2.4	Connection of multiple drives with the same power supply .....	57

7.2.5	Power supply wiring recommendations.....	58
7.2.5.1	Wire section .....	58
7.2.5.2	Wire ferrules .....	58
7.2.5.3	Wire length .....	59
7.3	Motor and shunt braking resistor.....	59
7.3.1	AC and DC brushless motors .....	59
7.3.2	DC motors and voice coils actuators .....	60
7.3.3	Motor wiring recommendations .....	62
7.3.3.1	Wire section .....	62
7.3.3.2	Wire ferrules .....	62
7.3.3.3	Motor choke .....	62
7.3.3.4	Wire length .....	63
7.3.4	Shunt braking resistor .....	63
7.4	Feedback connections.....	64
7.4.1	Digital Halls interface.....	65
7.4.2	Analog Halls interface.....	67
7.4.3	Digital Incremental Encoder.....	69
7.4.3.1	Digital encoders with single ended 24 V outputs .....	72
7.4.4	Analog encoder (Sin-Cos encoder) interface.....	72
7.4.5	Absolute encoder interface .....	74
7.4.6	Digital input feedback - PWM encoder.....	75
7.4.7	Analog input feedback.....	77
7.4.7.1	Potentiometer .....	77
7.4.7.2	DC tachometer .....	77
7.4.8	Feedback wiring recommendations .....	78
7.4.8.1	Recommendations for applications witch close feedback and motor lines .....	78
7.5	I/O connections.....	79
7.5.1	General purpose single ended digital inputs interface (GPI1, GPI2, GPI3, GPI4).....	79
7.5.2	High-speed digital inputs interface (HS_GPI1, HS_GPI2) .....	82
7.5.3	Analog inputs interface (AN_IN1, AN_IN2).....	87
7.5.4	Digital outputs interface (GPO1, GPO2,GPO3,GPO4) .....	90
7.5.4.1	Wiring of 5V loads.....	91
7.5.4.2	Wiring of 24V loads.....	92
7.5.5	Motor brake output (GPO1, GPO2, GPO3, GPO4) .....	94
7.5.6	Motor temperature input (MOTOR_TEMP) .....	95
7.6	Command sources .....	96
7.6.1	Network communication interface.....	97
7.6.2	Standalone .....	97
7.6.3	Analog input.....	98
7.6.4	Step and direction.....	99
7.6.5	PWM command .....	100
7.6.5.1	Single input mode.....	101
7.6.5.2	Dual input mode .....	102
7.6.6	Encoder following or electronic gearing.....	103
7.7	Communications.....	104
7.7.1	USB interface.....	104
7.7.1.1	USB powered drive .....	105
7.7.1.2	USB wiring recommendations .....	105
7.7.2	RS485 interface .....	105
7.7.2.1	Multi-point connection using daisy chain .....	107
7.7.3	CANopen interface .....	108

7.7.3.1	CAN interface for PC.....	110
7.7.3.2	CAN wiring recommendations .....	110
7.7.4	EtherCAT interface .....	111
7.8	Safe Torque Off (STO) .....	112
<b>8</b>	<b>Dimensions</b>	<b>115</b>
8.1	Triton Go with CAN (TRI-x/48-C-C) .....	115
8.2	Triton Go with EtherCAT (TRI-x/48-E-C) .....	116
<b>9</b>	<b>Application Software</b>	<b>118</b>
9.1	Configuration .....	118
9.2	Applications.....	118
9.3	Arduino .....	118
<b>10</b>	<b>Service</b>	<b>119</b>

## 2 General Information

### 2.1 Manual revision history

Revision	Release Date	Changes	PDF
v1	July 2016	Preliminary draft.	--
v2	November 2016	First public manual. Major corrections.	--
v3	February 2017	Minor improvements. Added wiring and connections information.	<a href="#">Download<sup>1</sup></a>
v4	May 2017	Improved PDF export format.	<a href="#">Download</a>

For the most up to date information use the online [Product Manual](#)<sup>2</sup>. The PDF manual is generated only after major changes.

Please refer to product [hardware revisions](#) (see page 16) page for information on previous hardware revisions and changes.

### 2.2 Disclaimers and limitations of liability

The information contained within this document contains proprietary information belonging to **INGENIA-CAT S.L.**

Such information is supplied solely for the purpose of assisting users of the product in its installation.

**INGENIA-CAT S.L.** rejects all liability for errors or omissions in the information or the product or in other documents mentioned in this document.

The text and graphics included in this document are for the purpose of illustration and reference only. The specifications on which they are based are subject to change without notice.

This document may contain technical or other types of inaccuracies. The information contained within this document is subject to change without notice and should not be construed as a commitment by **INGENIA-CAT S.L.** **INGENIA-CAT S.L.** assumes no responsibility for any errors that may appear in this document.

Some countries do not allow the limitation or exclusion of liability for accidental or consequential damages, meaning that the limits or exclusions stated above may not be valid in some cases.

### 2.3 Contact

INGENIA-CAT S.L.  
8-14 Marie Curie  
Advanced Industry Park  
08042 Barcelona  
Spain

<sup>1</sup> <http://ingeniamc.com/support/triton>

<sup>2</sup> <http://doc.ingeniamc.com/display/TR>

Telephone: +34 932 917 682

E-mail: [hello@ingeniamc.com](mailto:hello@ingeniamc.com)<sup>3</sup>

Web site: [www.ingeniamc.com](http://www.ingeniamc.com)<sup>4</sup>

---

<sup>3</sup> <mailto:HELLO@INGENIAMC.COM>

<sup>4</sup> <http://www.ingeniamc.com/>

## 3 Safety Information

### 3.1 About this manual

Read carefully this chapter to raise your awareness of potential risks and hazards when working with the Triton Servo Drive.

To ensure maximum safety in operating the Triton Servo Drive, it is essential to follow the procedures included in this guide. This information is provided to protect users and their working area when using the Triton Servo Drive, as well as other hardware that may be connected to it. Please read this chapter carefully before starting the installation process.

### 3.2 Warnings

The following statements should be considered to avoid serious injury to those individuals performing the procedures and/or damage to the equipment:

- To prevent the formation of electric arcs, as well as dangers to personnel and electrical contacts, never connect/disconnect the Triton Servo Drive while the power supply is on.
- Disconnect the Triton Servo Drive from all power sources before proceeding with any possible wiring change.
- After turning off the power and disconnecting the equipment power source, wait at least 10 seconds before touching any parts of the controller that are electrically charged or hot.

### 3.3 Precautions

The following statements should be considered to avoid serious injury to those individuals performing the procedures and/or damage to the equipment:

- The Triton Servo Drive components temperature may exceed 100 °C during operation.
- Some components become electrically charged during and after operation.
- The power supply connected to this controller should comply with the parameters specified in this document.
- When connecting the Triton Servo Drive to an approved power source, do so through a line that is separate from any possible dangerous voltages, using the necessary insulation in accordance with safety standards.
- High-performance motion control equipment can move rapidly with very high forces. Unexpected motion may occur especially during product commissioning. Keep clear of any operational machinery and never touch them while they are working.
- Do not make any connections to any internal circuitry. Only connections to designated connectors are allowed.
- All service and maintenance must be performed by qualified personnel.
- Before turning on the Triton Servo Drive, check that all safety precautions have been followed, as well as the installation procedures.

## 4 Product Description

The Triton Go Servo Drive is an ultra-compact solution providing top performance, advanced networking and built-in safety, as well as a fully featured motion controller. It can control multiple motor types and supports almost any feedback sensor including absolute serial encoders.

Its incredibly compact design includes multiple communication ports carrying [CANopen protocol](#)<sup>5</sup>, and thus enabling a wide choice of interfacing methods. Its small form factor, its capability to operate up to 110 °C and the bunch of features that come packed with it makes Triton a valid OEM for critical-size applications.

The Triton Go Servo Drive has been designed with efficiency in mind. It incorporates cutting-edge MOSFET technology as well as optimized control algorithms to provide the perfect trade-off between EMI and performance.

Triton Go Servo Drive is provided with several general purpose inputs and outputs designed for 5 V TTL logic but tolerant up to 24 V and fully rugged. By using these inputs and outputs it is possible to implement alarm signals, connect digital sensors, activate external devices (LEDs, actuators, solenoids, etc.). Some of the digital and analog inputs can also be used as command / target sources.



### 4.1 Triton part numbering

---

<sup>5</sup> <http://doc.ingeniamc.com/display/EMCL/CANopen+protocol>



## TRI-x/xx-y-C

**Power rating:** \_\_\_\_\_  
 7/48 = 6.3 A cont. / 8.5 A peak @ 48 Vdc nominal  
 4/48 = 5 A cont. / 5 A peak @ 48 Vdc nominal  
 1/48 = 1 A cont. / 1 A peak @ 48 Vdc nominal

**Communication interfaces:** \_\_\_\_\_  
 C = CAN / USB / RS-485  
 E = EtherCAT / USB / RS-485

**Connectors:** \_\_\_\_\_  
 C = Connector board with terminal blocks (Triton Go)  
 P = Pin headers (Triton Core)

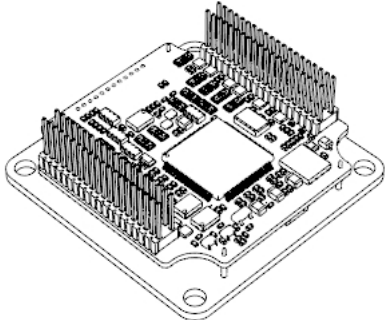
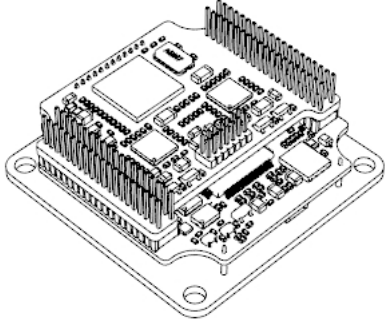
Product	Ordering part number	Status	Image
Triton Core <sup>6</sup>	TRI-7/48-C-P	ACTIVE	
	TRI-4/48-C-P	ACTIVE	
	TRI-1/48-C-P	ACTIVE	
Triton Go	TRI-7/48-E-P	ACTIVE	
	TRI-4/48-E-P	ACTIVE	
	TRI-1/48-E-P	ACTIVE	

<sup>6</sup> <http://doc.ingeniamc.com/display/TR/Triton+Core+Product+Manual>

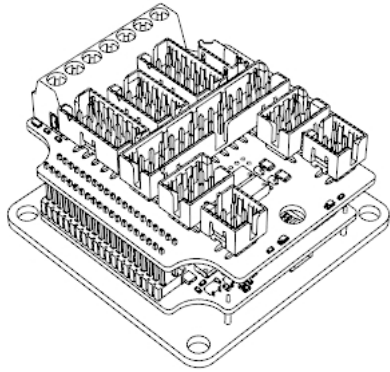
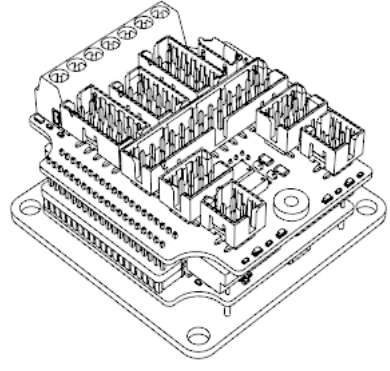
Triton Go	TRI-7/48-C-C	ACTIVE	
	TRI-4/48-C-C	ACTIVE	
	TRI-1/48-C-C	ACTIVE	
	TRI-7/48-E-C	ACTIVE	
	TRI-4/48-E-C	ACTIVE	
	TRI-1/48-E-C	ACTIVE	

**Changes in Part Numbers**

Part numbers have changed from version **1.0.0** due to a current re-scaling of the whole product range. Follow this equivalence to identify your old Triton:

- **Version 1.0.0 → 1.1.0 or later**
- TRI-8/48-C-P → TRI-7/48-C-P
- TRI-2/48-C-P → TRI-4/48-C-P
- TRI-0.5/48-C-P → TRI-1/48-C-P
- TRI-8/48-E-P → TRI-7/48-E-P
- TRI-2/48-E-P → TRI-4/48-E-P
- TRI-0.5/48-E-P → TRI-1/48-E-P
- TRI-8/48-C-C → TRI-7/48-C-C
- TRI-2/48-C-C → TRI-4/48-C-C
- TRI-0.5/48-C-C → TRI-1/48-C-C
- TRI-8/48-E-C → TRI-7/48-E-C
- TRI-2/48-E-C → TRI-4/48-E-C
- TRI-0.5/48-E-C → TRI-1/48-E-C

**4.2 Specifications**

A list of features of the Triton Go Servo Drive is shown next.

<b>Electrical and power specifications</b>			
<b>Part number</b> →	<b>TRI-1/48-y-C</b>	<b>TRI-4/48-y-C</b>	<b>TRI-7/48-y-C</b>
<b>Power supply voltage</b>	+8 V <sub>DC</sub> to +48 V <sub>DC</sub>		
<b>Transient peak voltage</b>	65 V <sub>DC</sub>		
<b>Internal DC bus capacitance</b>	20 μF		
<b>Minimum motor inductance</b>	200 μH (Triton still can control motors with lower inductances. Check our <a href="#">Knowledge Base</a> <sup>7</sup> )		
<b>Nominal phase continuous current (BLDC mode)</b>	0.67 A <sub>RMS</sub>	3.33 A <sub>RMS</sub> (with heatsink)	5.6 A <sub>RMS</sub> (with heatsink)
<b>Nominal phase continuous current (DC mode)</b>	1 A <sub>DC</sub>	5 A <sub>DC</sub> (with heatsink)	6.3 A <sub>DC</sub> (with heatsink)
<b>Maximum phase peak current</b>	1 A <sub>DC</sub> (continuous)	5 A <sub>DC</sub> (continuous, with heatsink)	8.5 A <sub>DC</sub> (5 s, with heatsink)
<b>Current sense range</b>	± 1.02 A	± 5.10 A	± 12.7 A
<b>Current sense resolution</b>	1.99 mA/ count	9.96 mA/count	24.8 mA/count
<b>Shunt braking transistor</b>	Shunt braking transistor on board. 8 A maximum current.		
<b>Cold plate</b>	1.5 mm aluminum sheet 6082-T6.		
<b>Power connectors</b>	Screw terminal block 3.5 mm pitch		
<b>Standby power consumption</b>	≤ 2.5 W (EtherCAT version TRI-x/48-E-C) ≤ 1.5 W (CAN version TRI-x/48-C-C)		
<b>Efficiency</b>	>96% at the rated power and current		

<sup>7</sup> <http://doc.ingeniamc.com/display/KB/Motor+inductance+effects+on+servo+drives>

<b>Motion control specifications</b>	
<b>Supported motor types</b>	<ul style="list-style-type: none"> <li>• Rotary brushless (trapezoidal and sinusoidal)</li> <li>• Linear brushless (trapezoidal and sinusoidal)</li> <li>• DC brushed</li> <li>• Rotary voice coil</li> <li>• Linear voice coil</li> </ul>
<b>Power stage PWM frequency</b>	20 kHz (default) 80 kHz (alternative PWM frequency, <a href="#">configurable</a> <sup>8</sup> )
<b>Current sensing</b>	Precision current sense on phases A, B. (Phase C is generated digitally) Accuracy is ± 1% full scale. 10 bit ADC resolution
<b>Sensors for commutation (brushless motors)</b>	<ul style="list-style-type: none"> <li>• Digital Halls (Trapezoidal)</li> <li>• Analog Halls (Sinusoidal / Trapezoidal)</li> <li>• Quad. Incremental encoder (Sinusoidal / Trapezoidal)</li> <li>• PWM encoder (Sinusoidal / Trapezoidal)</li> <li>• Analog potentiometer (Sinusoidal / Trapezoidal)</li> <li>• Sin-Cos encoder (Sinusoidal / Trapezoidal)</li> <li>• Absolute encoder SSI over RS-485 (Sinusoidal / Trapezoidal)</li> </ul>
<b>Sensors for servo loops</b>	<ul style="list-style-type: none"> <li>• Digital Halls</li> <li>• Analog Halls</li> <li>• Quad. Incremental encoder</li> <li>• PWM encoder</li> <li>• Analog potentiometer</li> <li>• Sin-Cos encoder</li> <li>• Absolute encoder SSI (over RS-485)</li> <li>• DC tachometer</li> </ul>

<sup>8</sup> <http://doc.ingeniamc.com/display/EMCL/0x2020+-+Enable+alternative+frequency+PWM>

<p><b>Supported target sources</b></p>	<ul style="list-style-type: none"> <li>• Network communication – USB</li> <li>• Network communication – CANopen</li> <li>• Network communication – RS-485</li> <li>• Network communication – EtherCAT</li> <li>• Standalone (execution from internal EEPROM memory)</li> <li>• Analog inputs</li> <li>• Step and Direction (Pulse and Direction)</li> <li>• PWM command</li> <li>• Encoder Following / Electronic Gearing</li> </ul>
<p><b>Inputs/outputs and protections</b></p>	
<p><b>General purpose Inputs and outputs</b></p>	<ul style="list-style-type: none"> <li>• 4 x non-isolated single-ended digital inputs. GPI1, GPI2, GPI3, GPI4 (5 V TTL logic, 24 V tolerant).</li> <li>• 2 x non-isolated high speed differential digital inputs. HS_GPI1, HS_GPI2 (5 V logic, 24 V tolerant).</li> <li>• 1 x (<math>\pm 10</math> V) differential analog input (12 bits). AN_IN2. (24 V tolerant).</li> <li>• 1 x 0 V... 5 V single ended analog input (12 bits). AN_IN1. (24 V tolerant).</li> <li>• 4 x open open drain digital outputs with a weak pull-up to 5 V. (24 V tolerant and 1 A; short-circuit and over-current protected).</li> </ul>
<p><b>Dedicated Inputs and outputs</b></p>	<ul style="list-style-type: none"> <li>• 2 x isolated Safe Torque Off inputs. 5 to 30 V inputs.</li> <li>• 4 x open collector LED output (50 mA maximum). See <a href="#">Signalling LEDs (see page 48)</a> section for more details.</li> </ul>
<p><b>Output Supplies</b></p>	<ul style="list-style-type: none"> <li>• 1 x 5 V output supply for powering external circuitry (up to 200 mA)</li> <li>• 1 x 3.3 V output supply for powering external circuitry (up to 50 mA)</li> </ul>

<p><b>Protections</b></p>	<ul style="list-style-type: none"> <li>• User configurable:                             <ul style="list-style-type: none"> <li>• DC bus over-voltage</li> <li>• DC bus under-voltage</li> <li>• Drive over-temperature</li> <li>• Drive under-temperature</li> <li>• Over-current</li> <li>• Overload (I<sup>2</sup>t)</li> </ul> </li> <li>• Short-circuit protections:                             <ul style="list-style-type: none"> <li>• Phase to DC bus</li> <li>• Phase to phase</li> <li>• Phase to GND</li> </ul> </li> <li>• Mechanical limits for homing functions</li> <li>• Hall sequence/combo error</li> <li>• ESD protections in all inputs, outputs, feedbacks and communications</li> <li>• EMI protections (noise filters) in all inputs, outputs and feedbacks</li> <li>• Supply inverse polarity protection</li> <li>• High power transient voltage suppressor (600 W peak TVS diode)</li> <li>• Can drive an external power braking resistor in case of re-injection (up to 7 A)</li> </ul>	
<p><b>Safe Torque Off</b></p>	<p>2x STO inputs, 5 V to 30 V isolated inputs</p>	
<p><b>Motor Brake</b></p>	<p>Motor brake output through a general purpose output (GPO1, GPO2, GPO3 or GPO4). Up to 24 V and 1 A.</p>	
<p><b>Communications</b></p>		
<p><b>Part number</b> →</p>	<p><b>TRI-x/48-C-C</b></p>	<p><b>TRI-x/48-E-C</b></p>
<p><b>USB</b></p>	<p>µUSB (2.0) vertical connector. The board can be supplied from USB for configuration purposes but will not power the motor.</p>	
<p><b>Serial</b></p>	<p>RS-485 full-duplex (compatible with RS-422), non-isolated. (default 115200 bps, 8 data bits, no parity, 1 stop bit, no flux control)</p>	

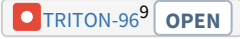
<b>CANopen</b>	Available. Non-isolated (1 Mbps by default). 120 Ω termination not included on board. CiA-301, CiA-303, CiA-305, CiA-306 and CiA-402 compliant.	-
<b>EtherCAT</b>	-	Available (magnetics included)
<b>Environmental and mechanical specifications</b>		
<b>Part number →</b>	<b>TRI-x/48-C-C</b>	<b>TRI-x/48-E-C</b>
<b>Cold plate temperature</b>	<ul style="list-style-type: none"> <li>-40 °C to +85 °C full current (with appropriate heatsink)  <a href="#">OPEN</a></li> <li>+85°C to 110°C <b>derated current</b></li> </ul>	
<b>Heat dissipation</b>	Heat dissipation is affected mainly by the phase current (see below)	
<b>Maximum humidity</b>	5% - 85% (non-condensing)	
<b>Horizontal dimensions</b>	43 mm x 45 mm	
<b>Maximum height</b>	23.5 mm	
<b>Weight (exc. mating connectors)</b>	34 g	42 g

 **Errata**

First version of the datasheet indicates a maximum phase peak current of 13 A<sub>RMS</sub> (2 s) which is incorrect. Also the TRI-4/48-y-C was underrated. Find the latest datasheet available [here](#)<sup>10</sup>.

<sup>9</sup> <https://ingeniamc.atlassian.net/browse/TRITON-96?src=confmacro>

<sup>10</sup> <http://ingeniamc.com/uploads/media/default/0001/01/4c83d7ac4a45382fd22cc82fc76750fa924ce036.pdf>

### 4.3 Hardware revisions

Hardware revision	Individual board references	Description and changes
<b>1.0.0</b> August 2016	i039-01H1-1.0.0 i039-01H2-1.0.0 i039-01H3-1.0.0	First product release.
<b>1.1.0</b> November 2016	i039-01H1-1.1.0 i039-01H2-1.0.0 i039-01H3-1.1.0	Changed product current range naming (current resolution and range is exactly the same as before) <ul style="list-style-type: none"> <li>• TRI-0.5/48 becomes TRI-1/48</li> <li>• TRI-2/48 becomes TRI-4/48</li> <li>• TRI-8/48 becomes TRI-7/48</li> </ul> Improved robustness of CAN / EtherCAT connectors. Features added: <ul style="list-style-type: none"> <li>• Analog Halls feedback</li> <li>• Analog (Sin-Cos) encoder feedback</li> <li>• RS-485 communications</li> </ul>

**i Identifying the hardware revision**

Hardware revision is screen printed on the board.

### 4.4 Power and current ratings

TRI-4/48-x-P and TRI-7/48-x-P variants of Triton go are capable of providing the nominal current from -25 °C to 85 °C (temperature measured in the coldplate) with a 1.2 °C/W heatsink attached by means of a low thermal resistance interface material. Above 85 °C a current derating is required. TRI-1/48-x-P, on the other hand, does not require a heatsink attached to reach its nominal current.

In case of excessive power losses over-temperature will be detected, causing the drive to turn off. The system temperature is available in [E-Core registers](#)<sup>11</sup> and is measured near the power stage. This temperature parameter can be accessed from USB 2.0, EtherCAT, CAN or RS485 serial interface and does not indicate the air temperature, but the temperature of the PCB. Above 110 °C the Triton Go automatically turns off the power stage and stay in fault state avoiding any damage to the drive. The Fault LED will be activated and latched until temperature decreases below this threshold.

<sup>11</sup><http://doc.ingeniamc.com/display/EMCL/0x20C2+-+Drive+temperature>



✔ Drive safety is always ensured by its protections. However, by means of it, power losses and temperature will limit the allowable motor current.

⚠ Some parts of the Triton Go can exceed 110 °C during operation, especially at high load levels. **Do not touch the Triton Go during operation** and wait at least 5 minutes after turn off to allow a safe cool down.

Following figure shows the basic power flow and losses in a servo drive system.

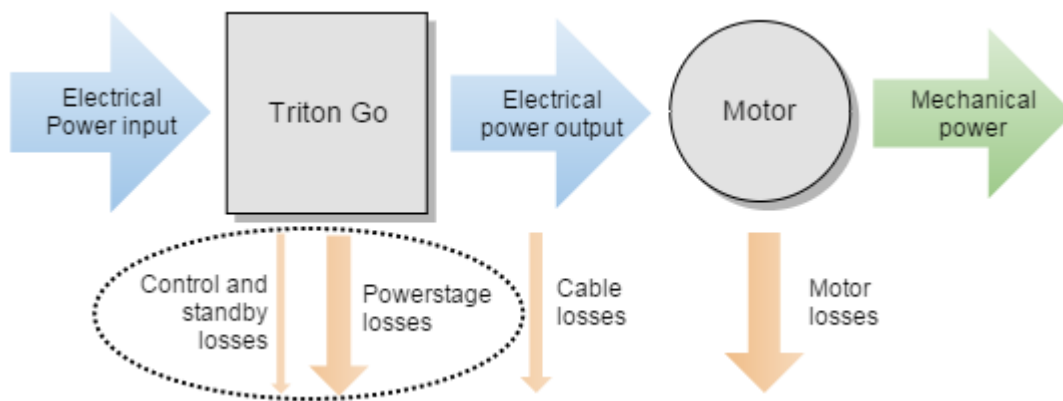

#### 4.4.1 Power losses calculation (heat dissipation)

Current flowing through Triton Servo Drive causes power losses that, ultimately, are converted in heat. This heat must be transferred to its surrounding environment efficiently, so that the temperature of the drive does not reach dangerous levels. The greater the power losses, the more effective the heat dissipation must be. Power losses mainly depend on 3 parameters:

- **Motor RMS current:** this is the cause of what are called *static* or *conduction* power losses, which typically are the main source of power losses, having that they show a positive correlation in a squared ratio.
- **DC bus voltage:** this, along with the motor RMS current and PWM switching frequency, is the cause of what are called *dynamic* or *commutation* losses, and show positive correlation in a proportional ratio.
- **PWM switching frequency:** similar to DC bus voltage, the PWM switching frequency directly affects the commutation losses. Typically, 20 kHz is the default value, but it can be increased up to 80 kHz.

#### ⓘ PWM switching frequency and nominal specifications

All nominal specifications in this manual are measured under a PWM switching frequency of 20 kHz.

Other less relevant parameters affect also the power losses but are not considered in the following graphs:

- **Air temperature:** higher power semiconductor temperatures reduce their efficiency.
- **Motor speed:** faster motor speeds result in higher overall power losses since the input DC bus current is greater, and this increases conduction losses on the reverse polarity protection circuitry.

## Power dissipation vs. motor current @ 48 V for TRI-7/48-x-C

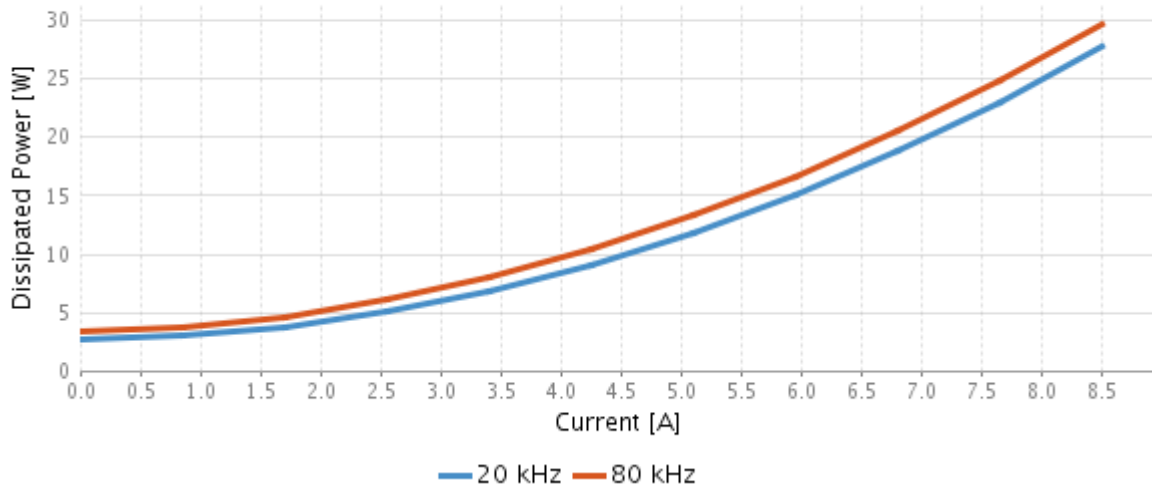

### 4.4.2 Current ratings

Power losses cause the drive to increase its temperature according to:

$$T_P \approx T_A + P_{LOSS} \cdot Z_{\theta PA}$$

As power losses have a positive correlation with the motor RMS current, when the ambient temperature rises, the output current must be limited to avoid an excessive drive temperature ( $T_P < 110\text{ }^\circ\text{C}$ ). The threshold temperature where the current derating should start mainly depends on the DC bus voltage. Then, although a  $1.2\text{ }^\circ\text{C/W}$  heatsink is required to reach the nominal current at the nominal DC bus voltage (48 V), the same nominal current can be reached with a less restrictive heatsink when DC bus voltage is lower. Also, other environmental parameters can relax the required heatsink thermal resistance to reach nominal current, typically:

- Air flow around the drive.
- Position (vertical allows natural convection).

Parameter	Value	Units	Notes
Maximum power stage temperature	110	$^\circ\text{C}$	Measured on the PCB (not the heatsink) and accessible via register.
Thermal resistance from power stage to heatsink	3.6	$^\circ\text{C/W}$	Does not consider the thermal resistance of the heatsink, but assumes the coldplate is a thermal conductor, not the thermal dissipator.
Thermal resistance from power stage to air	13	$^\circ\text{C/W}$	Considering the coldplate acting as the thermal dissipator (no heatsink attached).

Temperature stabilization time	> 60	s	With 1.2 °C/W heatsink attached. Considering 90 % of maximum temperature.
--------------------------------	------	---	---

This graphic shows the maximum current with respect to coldplate temperature, assuming a 1.2 °C/W heatsink attached.

### Maximum current vs. coldplate temperature for TRI-7/48-x-C

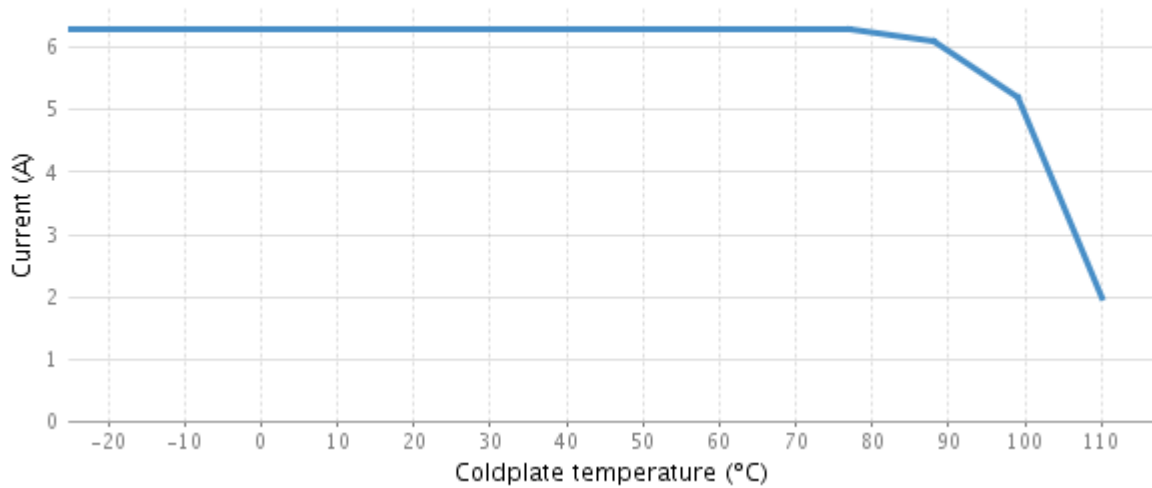

This graphic shows the maximum current with respect to ambient temperature, also assuming a 1.2 °C/W heatsink attached.

### Maximum current vs. ambient temperature for TRI-7/48-x-C

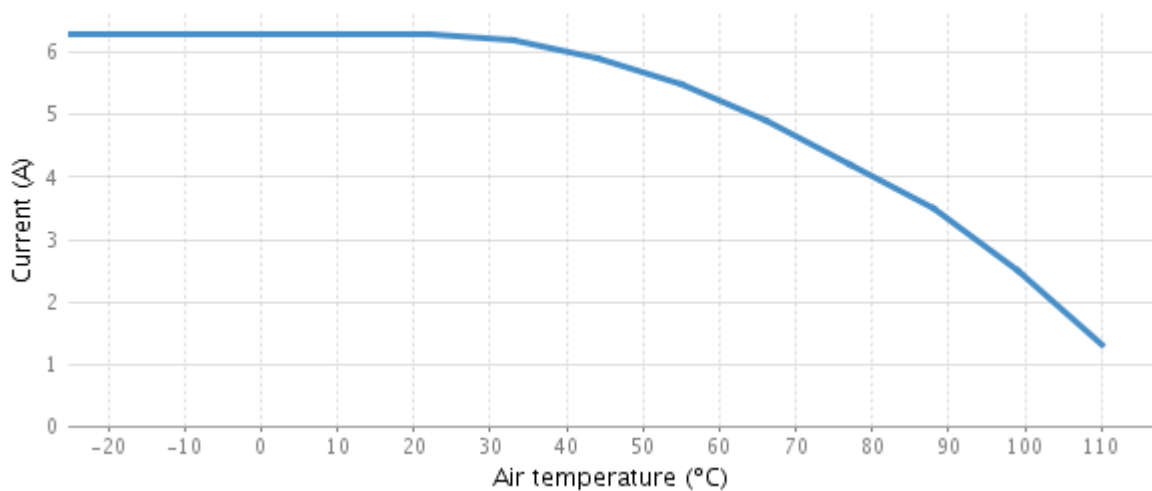

**⚠ Current derating**

The current derating graph is only indicative and is based on thermal tests performed in a climatic chamber where there was enough room for natural air convection. Each application may reach different ratings depending on the installation, ventilation and/or housing.

Current derating is only a recommendation and is not performed automatically by the drive.

**4.4.3 System temperature**

Triton power stage integrates power MOSFET transistors. Switching them means charging and discharging the those capacitors, and this is done thousands of times per second which results in power losses and a temperature increase even at 0 current. Therefore, a PCB temperature of 60 °C or more might be measured, even while no current is passing through the motor, specially if the drive is not ventilated at all.

**Recommendation: when motor is off, exit motor enable mode, as this will switch off the power stage.**

**4.4.4 Improving heat dissipation with a heatsink**

A heatsink is required to reach the nominal current at any ambient temperatures (except for TRI-1/48-x-C). When using high efficiency heatsinks or in enclosed spaces the equation can be simplified as follows.

$$T_P \approx T_A + P_{LOSS} \cdot (Z_{\theta PC} + Z_{\theta CH} + Z_{\theta HA})$$

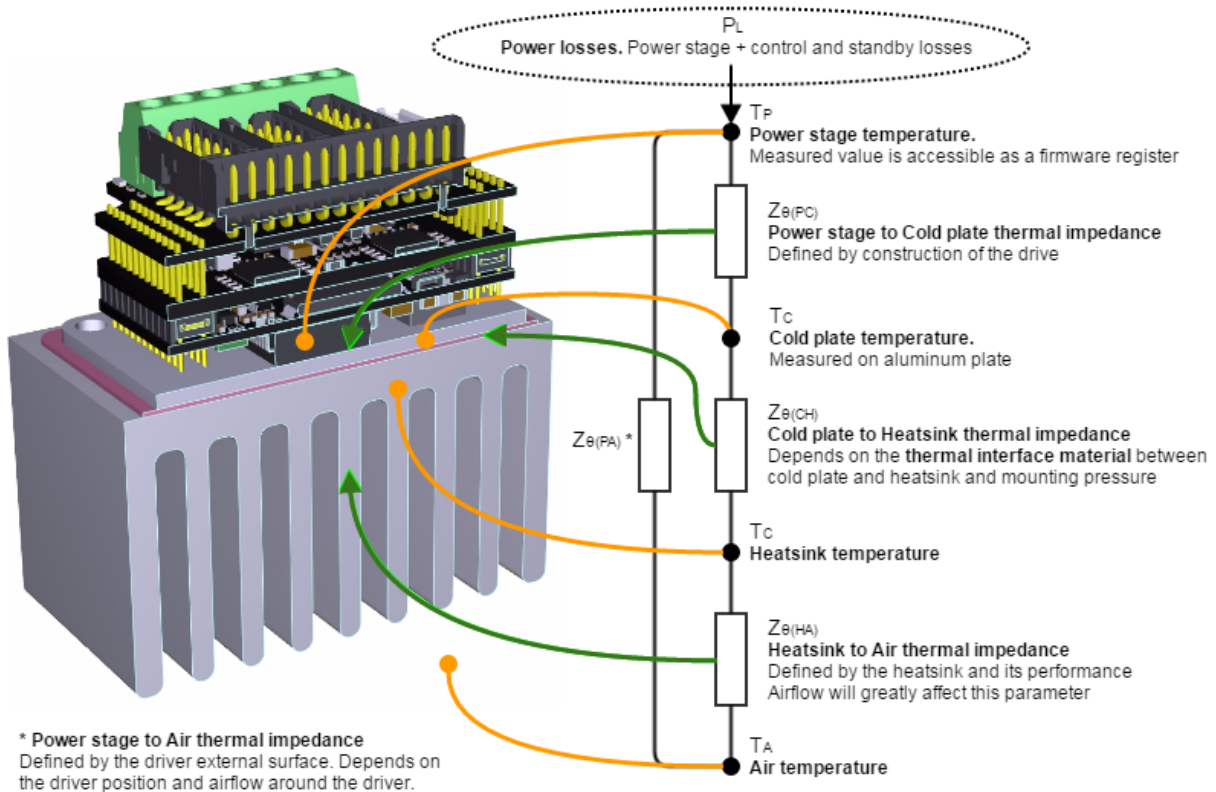

✔ **Assembly recommendations for best heat dissipation**

- Always allow natural air convection by ensuring  $\geq 10$  mm air space around the drive.
- Place Triton in inverted vertical position (with heatsink face up).
- Use a good thermal interface material to improve the heat dissipation.
- If housed, use a good thermal conductivity material, such as black anodized aluminum. Placing the drive in a small plastic package will definitively reduce its temperature range.
- Temperature range can be increased by providing forced cooling with a fan. **Always ensure electrical isolation between live parts and the heatsink.**

#### 4.5 Architecture

This diagram represent the main hardware elements of Triton Go, and how they relate to each other.

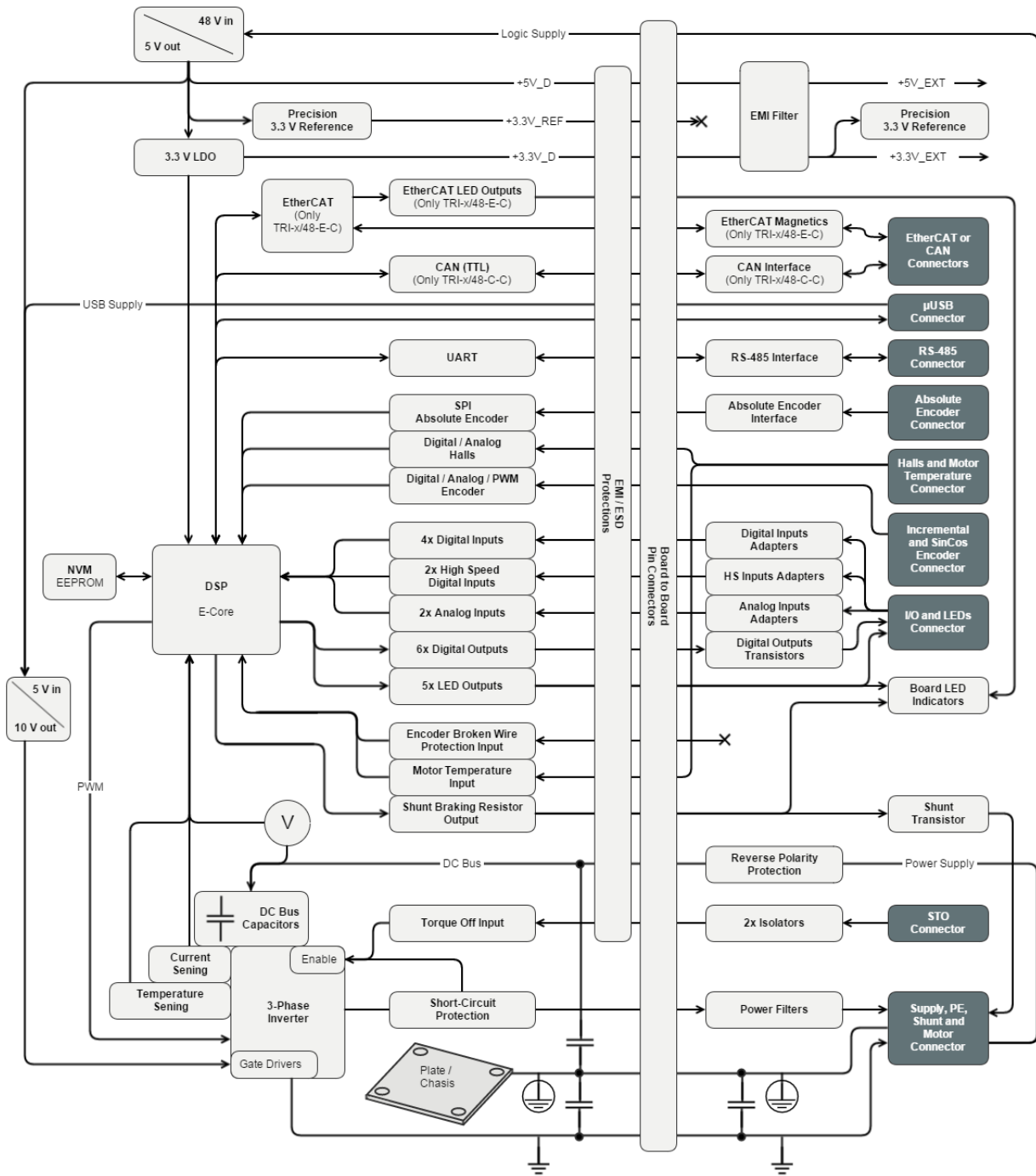

## 5 Connectors Guide

This chapter details the Triton Go Servo Drive (TRI-x/48-y-C) connectors and pinout. For a pin header board option please refer to the [Triton Core<sup>12</sup>](#) product manual.

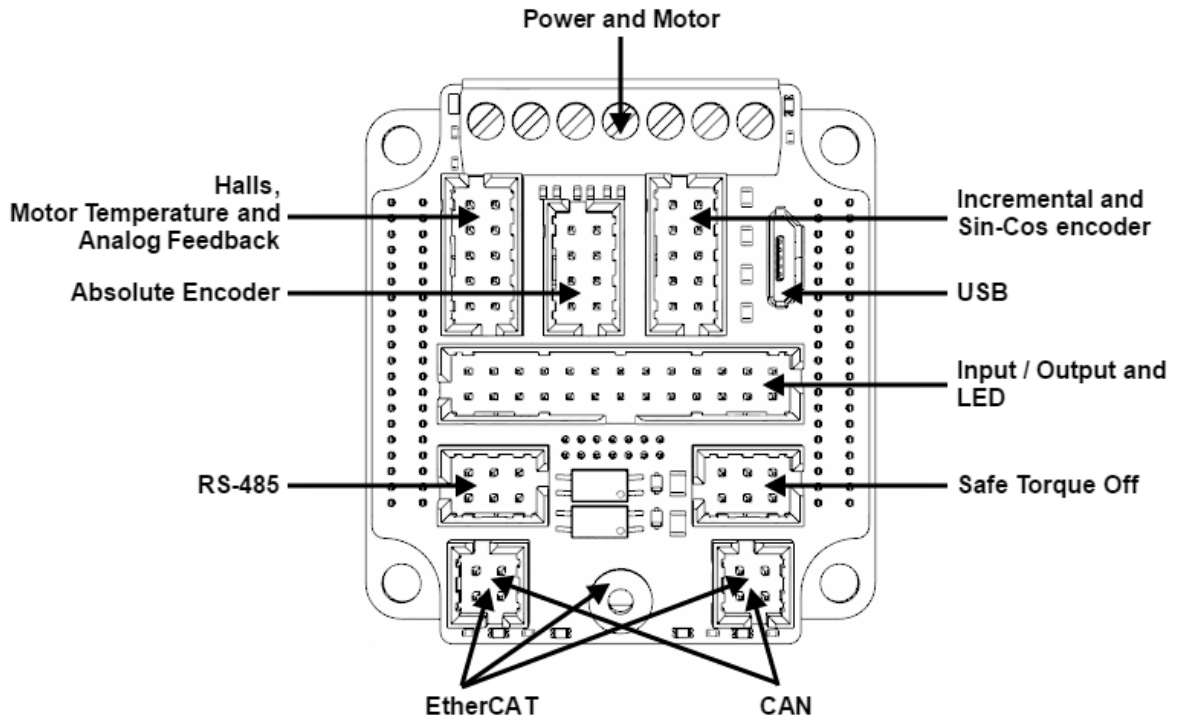

<sup>12</sup><http://doc.ingeniamc.com/display/TR/Triton+Core+Product+Manual>

### 5.1 Supply, shunt and motor connector

#### P1 Connector

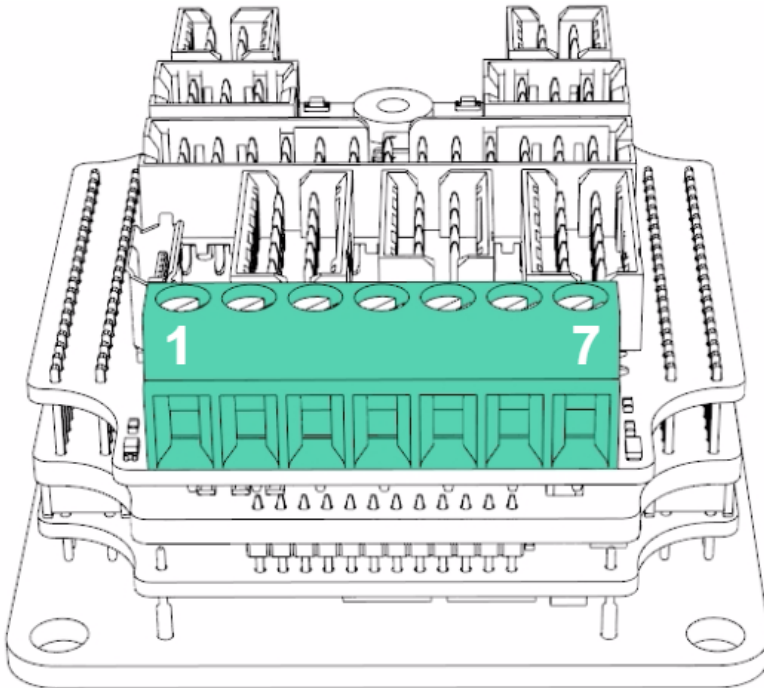

7 position, 3.5 mm pitch rising cage clamp terminal block. [Phoenix Contact 1751293](https://www.phoenixcontact.com/online/portal/us?uri=pxc-oc-itemdetail:pid=1751293)<sup>13</sup>.

Pin	Signal	Function
1	PH_A	Motor phase A (Positive for DC and voice coils)
2	PH_B	Motor phase B (Negative for DC and voice coils)
3	PH_C	Motor phase C (Do not connect for DC and voice coils)
4	PE	Protective earth connection, internally connected to standoffs and drive cold plate.
5	GND_P	Ground connection
6	SHUNT_OUT	Shunt braking transistor output (Shunt resistor should be connected between POW_SUP and SHUNT_OUT)



<sup>13</sup> <https://www.phoenixcontact.com/online/portal/us?uri=pxc-oc-itemdetail:pid=1751293>



7	POW_SU P	Power supply positive
<b>Notes</b>		
<ul style="list-style-type: none"> <li>• Dimension the wiring according to the application current ratings. Higher section is always preferred to minimize resistance and wire self-heating.</li> <li>• Recommended wire section is 0.5 mm<sup>2</sup> ~ 1.5 mm<sup>2</sup></li> <li>• For wiring information, see <a href="#">power supply wiring</a> (see page 55), <a href="#">motor and shunt braking resistor</a> (see page 59) and <a href="#">protective earth</a> (see page 52) wiring sections.</li> </ul>		

## 5.2 Milli-Grid connectors mating

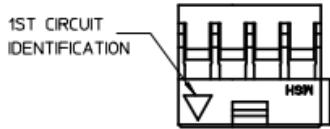
All Triton Go Servo Drive signal and communication connections are based in Molex Milli-Grid™ 2 mm pitch connectors. Multi-core crimped cables can be used for wiring inputs, outputs feedbacks and communications.

Multi-core crimped cable mating	
Description	Molex Milli-Grid™ Receptacle Housing, 2.00mm Pitch, with Center Locking Ramp and Side Polarization Keys.
Image	 <p>Triangle on the bottom left indicates pin 1.</p>
Crimp terminals	
Description	Milli-Grid™ Crimp Terminal, Female, 0.38µm Select Gold, Reel, Lead free
Image	
Part number	Molex 50394-8051
Distributor codes	Farnell <a href="#">2293846</a> <sup>14</sup> Digi-Key <a href="#">WM1128CT-ND</a> <sup>15</sup> Mouser <a href="#">538-50394-8051</a> <sup>16</sup>

<sup>14</sup> <http://es.farnell.com/molex/50394-8051/contact-crimp-receptacle-30-24awg/dp/2293846>

<sup>15</sup> <http://www.digikey.es/product-detail/en/molex-llc/0503948051/WM1128CT-ND/467814>

<sup>16</sup> <http://www.mouser.es/ProductDetail/Molex/50394-8051/?qs=sGAEpiMZZMs%252bGHln7q6pm%252bS0pk2Wo0Xx4udesc6psEE%3d>

Pre-assembled wires	
Description	Black 26 AWG pre-crimped jumper cable (50.8 mm). Note: there are many lengths and clours available at <a href="#">Digi-Key</a> <sup>17</sup> .
Part number	Molex 0503948051-02-B6
Distributor codes	Digi-Key <a href="#">0503948051-02-B6-ND</a> <sup>18</sup>

**! Connection and disconnection of connectors**

Take special care when disconnecting cables. Cables must be disconnected vertically. Failing to do so may damage your drive.

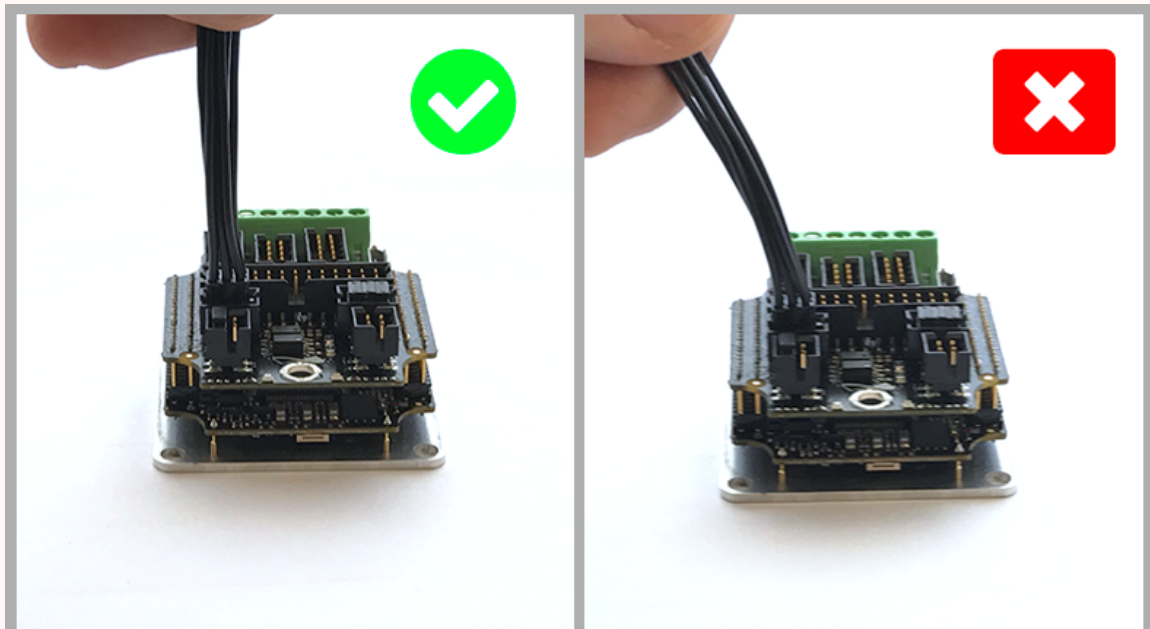

<sup>17</sup> <http://www.digikey.es/product-search/en/cable-assemblies/jumper-wires-pre-crimped/1573153?k=&pkeyword=&s=5519&FV=fffc0384%2Cfff40018%2Cfff80121%2C780001&mnonly=0&newproducts=0&ColumnSort=0&page=1&stock=1&pbfree=1&rohs=1&quantity=0&ptm=0&fid=0&pageSize=25>

<sup>18</sup> <http://www.digikey.ca/product-detail/en/molex-llc/0503948051-02-B6/0503948051-02-B6-ND/6047275>

### 5.3 Halls and motor temperature connector

**P2 Connector**

10 pin 2 row Milli-Grid™ 2 mm pitch header. [Molex 87832-1006](http://www.molex.com/molex/products/datasheet.jsp?part=active/0878321006_PCB_HEADERS.xml)<sup>19</sup>

Pin	Signal	Function
1	PE	Cable shield connection (Internally connected to drive mounting plate)
2	+5V_OUT	5 V 200 mA max (shared with other connectors)
3	GND_D	Ground
4	MOTOR_TEMP	Motor temperature sensor connection (connect the other terminal to GND_D on pin 5). Includes a pull-up to 3.3 V. The pin is connected to analog input 3.
5	GND_D	Ground
6	NC	Do not connect

<sup>19</sup>[http://www.molex.com/molex/products/datasheet.jsp?part=active/0878321006\\_PCB\\_HEADERS.xml](http://www.molex.com/molex/products/datasheet.jsp?part=active/0878321006_PCB_HEADERS.xml)

7	HALL_1	Hall sensor input 1 (analog and digital)
8	HALL_2	Hall sensor input 2 (analog and digital)
9	GND_D	Ground
10	HALL_3	Hall sensor input 3 (analog and digital)

**Notes**

- The drive includes 1 kΩ pull-up resistors to the halls inputs. They are enabled when digital halls are selected.
- See [Feedback connections \(see page 64\)](#) for further information about different feedbacks wiring.

**⚠ Do not confuse with encoder connector**

Halls and encoder connectors have the same number of pins. Take due precautions not to connect them incorrectly.

**Mating**

Description	2.00mm Pitch, Milli-Grid™ Receptacle Housing, 10 Circuits, with Center Locking Ramp and Side Polarization Keys.
Image	
Part number	Molex 51110-1056
Distributor code	Mouser <a href="#">538-51110-1056</a> <sup>20</sup>

**Notes**

- Triangle on the bottom left indicates pin 1.
- See [Milli-Grid connectors mating \(see page 25\)](#) for further information about crimping terminals and cables.

<sup>20</sup><http://www.mouser.es/ProductDetail/Molex/51110-1056/?qs=%2fha2pyFaduiMjkwvWmWuOZY0mFhuCLeDSv3wJ9%2f1J325nRN%2fRFKkgQ%3d%3d>

### 5.4 Absolute encoder connector

**P3 Connector**

8 pin 2 row Milli-Grid™ 2 mm pitch header. [Molex 87832-0806](http://www.molex.com/molex/products/datasheet.jsp?part=active/0878320806_PCB_HEADERS.xml)<sup>21</sup>

Pin	Signal	Function
1	PE	Cable shield connection (Internally connected to drive mounting plate)
2	+3.3V_OUT	+3.3 V 200 mA max for absolute encoder
3	+5V_OUT	+5V 200mA max supply for absolute encoder (shared with other connectors)
4	GND_D	Ground connection
5	CLK+	Absolute encoder CLK positive signal output
6	CLK-	Absolute encoder CLK negative signal output
7	DATA+	Absolute encoder DATA positive signal input

<sup>21</sup>[http://www.molex.com/molex/products/datasheet.jsp?part=active/0878320806\\_PCB\\_HEADERS.xml](http://www.molex.com/molex/products/datasheet.jsp?part=active/0878320806_PCB_HEADERS.xml)

8	DATA-	Absolute encoder DATA negative signal input
<b>Notes</b>		
<ul style="list-style-type: none"> <li>The Triton is compatible both with 5 V and 3.3 V level absolute encoders. The input accepts also single ended signals, in this case, connect clock and data positive signals only.</li> <li>See <a href="#">Feedback connections</a> (see page 64) for further information about different feedbacks wiring.</li> </ul>		

<b>Mating</b>	
Description	2.00mm Pitch, Milli-Grid™ Receptacle Housing, 8 Circuits, with Center Locking Ramp and Side Polarization Keys.
Image	
Part number	Molex 51110-0856
Distributor code	Mouser <a href="#">538-51110-0856</a> <sup>22</sup>
<b>Notes</b>	
<ul style="list-style-type: none"> <li>Triangle on the bottom left indicates pin 1.</li> <li>See <a href="#">Milli-Grid connectors mating</a> (see page 25) for further information about crimping terminals and cables.</li> </ul>	

<sup>22</sup><http://www.mouser.es/ProductDetail/Molex/51110-0856/?qs=%2fha2pyFadujpLMvCViSBh7%2flihvZWic%252baUGAy893gmEX40zenQ8%252b%252bQ%3d%3d>

### 5.5 Incremental and Sin-Cos encoder connector

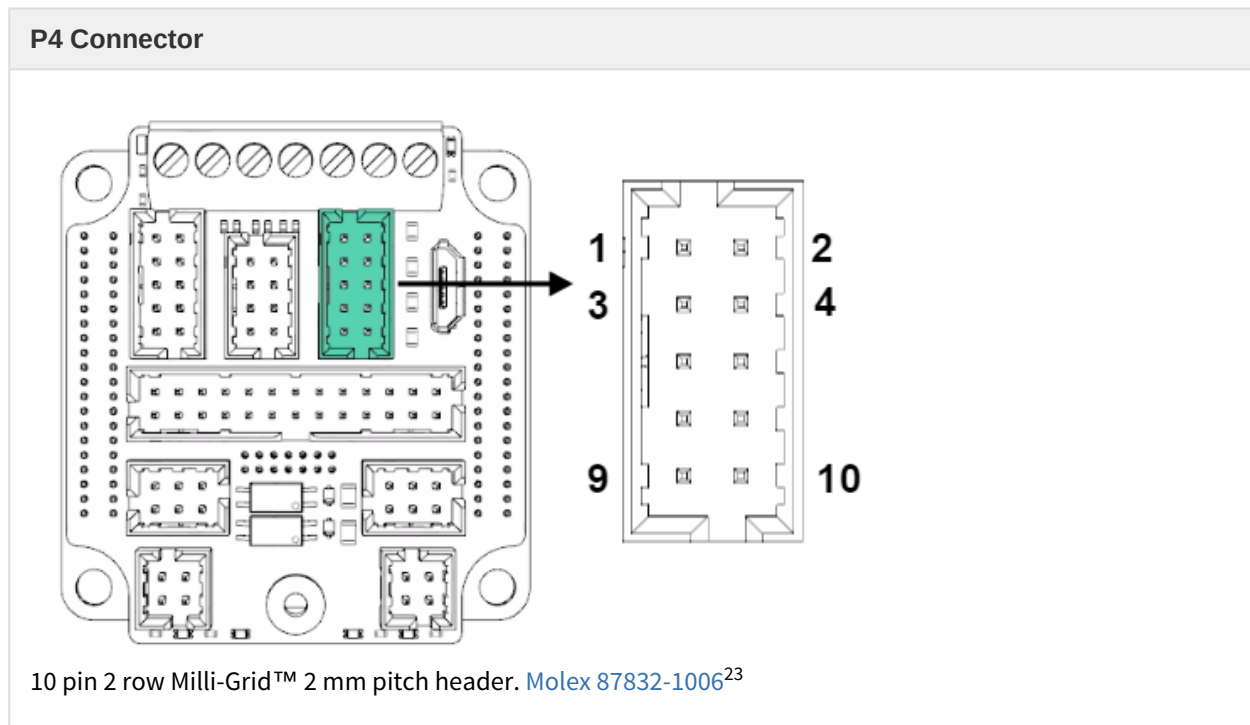

Pin	Signal	Function
1	PE	Cable shield connection (Internally connected to mounting plate)
2	+5V_OUT	5 V 200 mA max (shared with other connectors)
3	GND_D	Ground
4	+3.3V_OUT	3.3 V 200 mA max supply output
5	ENC_A-	Differential Encoder: A- input
6	ENC_A+	Single ended digital encoder: A input Differential digital encoder: A+ input
7	ENC_B-	Differential Encoder: B- input
8	ENC_B+	Single ended digital encoder: B input Differential digital encoder: B+ input

<sup>23</sup> [http://www.molex.com/molex/products/datasheet.jsp?part=active/0878321006\\_PCB\\_HEADERS.xml](http://www.molex.com/molex/products/datasheet.jsp?part=active/0878321006_PCB_HEADERS.xml)

9	ENC_Z-	Differential Encoder: Index- input
10	ENC_Z+	Single ended digital encoder: Index input Differential digital encoder: Index+ input
<b>Notes</b>		
<ul style="list-style-type: none"> <li>See <a href="#">Feedback connections</a> (see page 64) for further information about different feedbacks wiring.</li> </ul>		
<p><b>⚠ Do not confuse with Halls connector</b></p> <p>Halls and encoder connectors have the same number of pins. Take care to not switch them.</p>		

<b>Mating</b>	
Description	2.00mm Pitch, Milli-Grid™ Receptacle Housing, 10 Circuits, with Center Locking Ramp and Side Polarization Keys.
Image	
Part number	Molex 51110-1056
Distributor code	Mouser <a href="#">538-51110-1056</a> <sup>24</sup>
<b>Notes</b>	
<ul style="list-style-type: none"> <li>Triangle on the bottom left indicates pin 1.</li> <li>See <a href="#">Milli-Grid connectors mating</a> (see page 25) for further information about crimping terminals and cables.</li> </ul>	

<sup>24</sup><http://www.mouser.es/ProductDetail/Molex/51110-1056/?qs=%2fha2pyFaduiMjkwvWmWuOZy0mFhuCLeDSv3wJ9%2f1J325nRN%2fRFKkgQ%3d%3d>



**5.6 USB connector**

**P5 Connector**

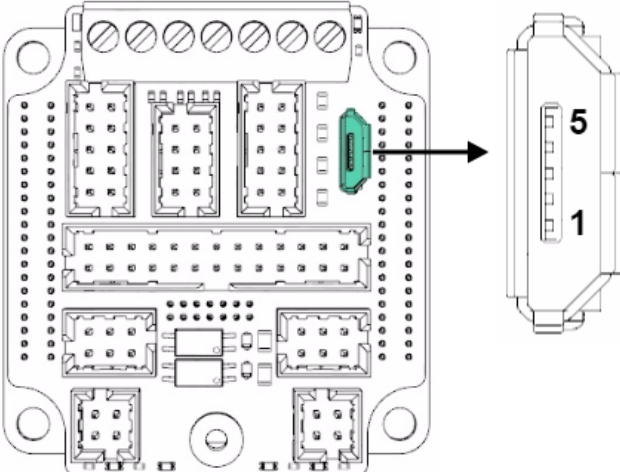

5 pin vertical micro-USB connector. [Wurth Electronics 614105150721](http://www.wurthelectronics.com/614105150721)<sup>25</sup>.

Pin	Signal	Function
1	USB_SUPPL Y	USB +5 V supply input. Used to power logic circuits when no external power supply is available.
2	USB D-	USB Data- line
3	USB D+	USB Data+ line
4	NC	Not connected
5	GND_D	Ground
SHI EL D	NC	Connector metallic shield, NOT CONNECTED.

<sup>25</sup> [http://katalog.we-online.de/en/em/COM\\_MICRO\\_TYPE\\_B\\_VERTICAL/614105150721](http://katalog.we-online.de/en/em/COM_MICRO_TYPE_B_VERTICAL/614105150721)

Notes
<ul style="list-style-type: none"> <li>• <b>Avoid applying excessive lateral forces to the USB connector.</b></li> <li>• Micro-USB connection allows drive configuration using <a href="#">Motion Lab</a><sup>26</sup> or downloading <a href="#">latest firmware revision</a><sup>27</sup>.</li> <li>• Shorter USB cables are preferred whenever possible for minimal EMI.</li> <li>• Please see <a href="#">Communications</a> (see page 104) page for further information</li> </ul>

Mating	
Description	USB Shielded I/O Cable Assembly, USB A-to-Micro-USB B, 1.50m Length, Black, Lead-Free
Image	
Part number	Molex 68784-0002
Distributor code	Mouser <a href="#">538-68784-0002</a> <sup>28</sup> Farnell <a href="#">1617586</a> <sup>29</sup>

<sup>26</sup> <http://ingeniamc.com/software#motionlab>

<sup>27</sup> <http://doc.ingeniamc.com/display/I071QUICKSTART/Update+Drive+Firmware>

<sup>28</sup> <http://www.mouser.es/ProductDetail/Molex/51110-1056/?qs=%2fha2pyFaduiMjkwWmWuOZy0mFhuCLeDSv3wJ9%2f1J325nRN%2fRFKKgQ%3d%3d>  
<http://www.mouser.es/ProductDetail/Molex/68784-0002/?qs=%2fha2pyFadujzmc7Hrcjf2BgIrT%2fRSoijj4vkovWYfZ89xZu3tIJQg%3d%3d>

<sup>29</sup> <http://es.farnell.com/molex/68784-0002/cable-ass-usb-a-to-micro-usb-b/dp/1617586>

### 5.7 I/O and LEDs connector

**P6 Connector**

26 pin 2 row Milli-Grid™ 2 mm pitch header. [Molex 878322620](http://www.molex.com/molex/products/datasheet.jsp?part=active/0878322620_PCB_HEADERS.xml)<sup>30</sup>



Pin	Signal	Function
1	PE	Cable shield connection (Internally connected to mounting plate)
2	GND_D	Ground
3	HS_GPI1- / PULSE- / PWM-	High speed digital differential input 1- Command source: Pulse- input Feedbacks: PWM- input
4	HS_GPI1+ / PULSE+ / PWM+	High speed digital differential input 1+ Command source: Pulse+ input Feedbacks: PWM+ input
5	HS_GPI2- / DIR-	High speed digital differential input 2- Command source: Direction- input
6	HS_GPI2+ / DIR+	High speed digital differential input 2+ Command source: Direction+ input

<sup>30</sup> [http://www.molex.com/molex/products/datasheet.jsp?part=active/0878322620\\_PCB\\_HEADERS.xml](http://www.molex.com/molex/products/datasheet.jsp?part=active/0878322620_PCB_HEADERS.xml)

7	GPI1	General purpose single ended digital input 1
8	GPI2	General purpose single ended digital input 2
9	GPI3	General purpose single ended digital input 3
10	GPI4	General purpose single ended digital input 4
11	GPO1	Digital output 1 (open collector with weak pull-up to 5 V, can be configured as brake driver)
12	GPO2	Digital output 2 (open collector with weak pull-up to 5 V, can be configured as brake driver)
13	GPO3	Digital output 3 (open collector with weak pull-up to 5 V, can be configured as brake driver)
14	GPO4	Digital output 4 (open collector with weak pull-up to 5 V, can be configured as brake driver)
15	GND_D	Ground
16	+5V_OUT	5 V 200 mA max (shared with other connectors)
17	NC	Not connected.
18	AN_IN1	Single ended analog input 1 (0 ~ 5 V).
19	AN_IN2-	Differential $\pm 10$ V analog inverting input 2 Single ended analog input 2 ground
20	AN_IN2+	Differential $\pm 10$ V analog non inverting input 2 Single ended analog input 2
21	GND_D	Ground
22	GND_D	Ground
23	LED_RUN_K	External CAN/ECAT Run LED (green) cathode. Connect anode to +5 V supply
24	LED_ERR_K	External CAN/ECAT Error LED (red) cathode. Connect anode to +5 V supply
25	LED_LINK1_K	External ECAT Link1 LED (yellow) cathode. Connect anode to +5 V supply
26	LED_LINK0_K	External ECAT Link0 LED (yellow) cathode. Connect anode to +5 V supply

Notes	
<ul style="list-style-type: none"> <li>• LED outputs are open collector with a 220 Ω resistor in series for current limiting. However the output is tolerant to 30 V and can be used with panel indicators powered at 12V or 24V, just ensure current does not exceed 25 mA.</li> <li>• All the inputs and outputs are tolerant to 30 V, therefore they can be wired to PLC interfaces.</li> <li>• See <a href="#">I/O connections</a><sup>31</sup> for further information about different I/O wiring.</li> </ul>	

I/O & LEDs connector presents a high number of pins and can be wired using ribbon cable or multi-core crimped cable.

Ribbon cable mating	
Description	Milli-Grid™ Cable-to-Board Receptacle, Dual Row, IDT, Lead-Free, 26 Circuits, 0.38µm Gold (Au) Selective Plating, with Center Polarization Key and Locking Friction Ramp
Image	 <p>Triangle on the bottom left indicates pin 1.</p>
Part number	Molex 87568-2693
Distributor code	Mouser <a href="#">87568-2693</a> <sup>32</sup> Farnell <a href="#">2112403</a> <sup>33</sup> Digi-Key <a href="#">WM14326-ND</a> <sup>34</sup>
Flat wire	
Description	Flat cable 26 conductors, 1 mm pitch, 28 AWG, stranded
Image	

<sup>31</sup> <http://doc.ingeniamc.com/pages/viewpage.action?pagelId=40666958>

<sup>32</sup> <http://www.mouser.es/ProductDetail/Molex/87568-2693/?qs=%2fha2pyFaduijcrGN%2fQheCLb8TMIMOIA%2f%2fmcI7W2Vpg%3d>

<sup>33</sup> <http://es.farnell.com/molex/87568-2693/connector-receptacle-2mm-26way/dp/2112403?ost=87568-2693&selectedCategoryId=&categoryNameResp=Todas%2Blas%2Bcategor%25C3%25ADas&searchView=table&isrfrnonsku=false>

<sup>34</sup> <http://www.digikey.es/product-search/es?keywords=87568-2693>

Part number	3M 3625/26-30M
Distributor code	Mouser <a href="#">517-3625/26</a> <sup>35</sup> Farnell <a href="#">2065102</a> <sup>36</sup>
<b>Notes</b>	
<div style="border: 1px solid green; padding: 10px;"> <p> <b>Easy wiring</b> Ribbon cable is the easiest and lowest cost option.</p> </div>	

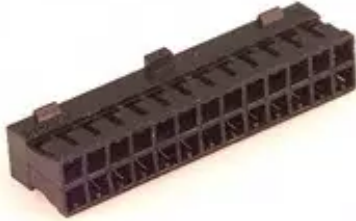
<b>Multi-core crimped cable mating</b>	
Description	2.00mm Pitch, Milli-Grid™ Receptacle Housing, 26 Circuits, with Center Locking Ramp and Side Polarization Keys.
Image	
Part number	Molex 51110-2651
Distributor code	Mouser <a href="#">538-511102651</a> <sup>37</sup> Farnell <a href="#">1393610</a> <sup>38</sup> Digi-Key <a href="#">WM18053-ND</a> <sup>39</sup>

<sup>35</sup> <http://www.mouser.es/ProductDetail/3M-Electronic-Solutions-Division/3625-26-30M/?qs=sGAEpiMZZMvAvBNgSS9Lqum1YXpLgsKz>

<sup>36</sup> <http://es.farnell.com/3m/3625-26/gu-a-gris-26w-1-mm-28awg-por-m/dp/2065102>

<sup>37</sup> <http://www.mouser.es/ProductDetail/Molex/51110-2651/?qs=%2fha2pyFaduiMjkwvWmWuOfg2KFJ0JOLHIWYrnz%2f4XQIAqMt94%2f8Y0g%3d%3d>

<sup>38</sup> <http://es.farnell.com/molex/51110-2651/crimp-housing-milli-grid-2mm-26way/dp/1393610?ost=51110-2651&selectedCategoryId=&categoryNameResp=Todas%2Blas%2Bcategor%25C3%25ADas&searchView=table&isrfrnonsku=false>

<sup>39</sup> <http://www.digikey.es/product-search/es?keywords=51110-2651>

**Notes**

- Triangle on the bottom left indicates pin 1.
- See [Milli-Grid connectors mating](#) (see page 25) for further information about crimping terminals and cables.

**✔ Clean wiring**

Crimped single cables makes wiring cleaner and is a preferred option for volume applications.

**5.8 RS485 interface connector**

**P7 Connector**

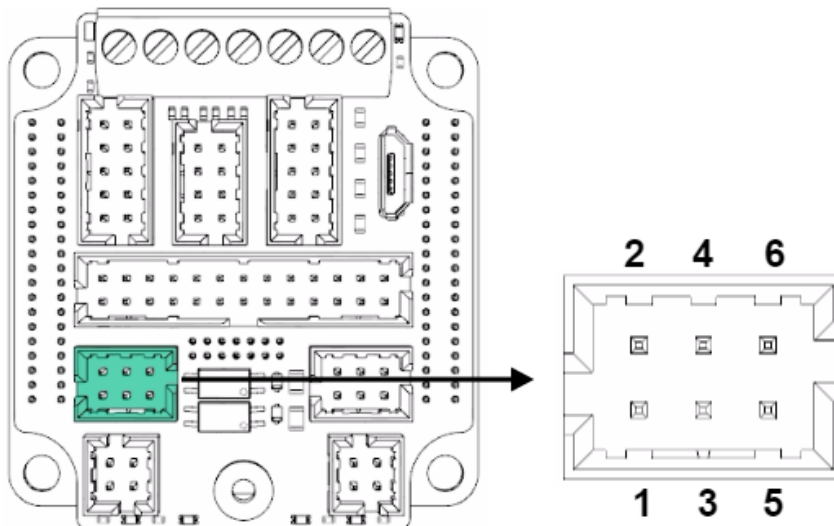

6 pin 2 row Milli-Grid™ 2 mm pitch header. [Molex 878320628](#)<sup>40</sup>

Pin	Signal	Function
1	PE	Cable shield connection (Internally connected to mounting plate)
2	GND_D	Ground
3	RX+	RS485 receive data + (should be connected to master TX+)
4	TX+	RS485 transmit data + (should be connected to master RX+)

<sup>40</sup> [http://www.molex.com/molex/products/datasheet.jsp?part=active/0878320628\\_PCB\\_HEADERS.xml](http://www.molex.com/molex/products/datasheet.jsp?part=active/0878320628_PCB_HEADERS.xml)

5	RX-	RS485 receive data - (should be connected to master TX-)
6	TX-	RS485 transmit data - (should be connected to master RX-)

**Notes**

- The Triton does not include any termination resistors to the RX or TX signals.
- The interface is full-duplex without specific data control and totally compatible with serial RS422.
- Please see [Communications](#) (see page 104) page for further information



**Do not confuse with STO connector**

RS485 and STO have the same number of pins. Take due precautions not to connect them incorrectly.



**Hardware revision 1.0.0**

RS485 was not available in hardware revision 1.0.0.

**Mating**

Description	2.00mm Pitch, Milli-Grid™ Receptacle Housing, 6 Circuits, with Center Locking Ramp and Side Polarization Keys.
Image	
Part number	Molex 51110-0656
Distributor code	Mouser <a href="#">538-51110-0656</a> <sup>41</sup>

**Notes**

- Triangle on the bottom left indicates pin 1.
- See [Milli-Grid connectors mating](#) (see page 25) for further information about crimping terminals and cables.

<sup>41</sup><http://www.mouser.es/ProductDetail/Molex/51110-1056/?qs=%2fha2pyFaduiMjkwvWmWuOZY0mFhuCLeDSv3wJ9%2f1J325nRN%2fRFKkgQ%3d%3d>



### 5.9 Safe Torque Off (STO) connector

**P8 Connector**

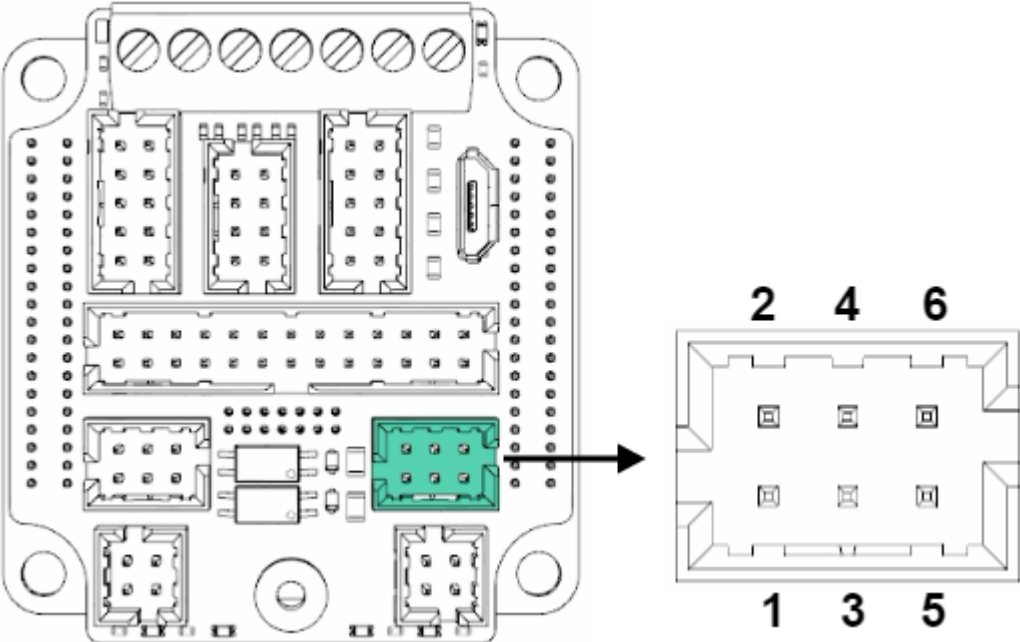

6 pin 2 row Milli-Grid™ 2 mm pitch header. [Molex 878320628](http://www.molex.com/molex/products/datasheet.jsp?part=active/0878320628)<sup>42</sup>

Pin	Signal	Function
1	STO_COMMON	Safe Torque Off common (optocoupler LEDs cathode, ISOLATED).
2	GND_D	Ground (not isolated)
3	STO_1	Safe Torque Off input 1 (positive, active from 5 V to 36 V, ISOLATED)
4	+5V_OUT	+5 V output, can be used for STO circuit.
5	STO_2	Safe Torque Off input 1 (positive, active from 5 V to 36 V, ISOLATED)
6	+5V_OUT	+5 V output, can be used for STO circuit.

<sup>42</sup> [http://www.molex.com/molex/products/datasheet.jsp?part=active/0878320628\\_PCB\\_HEADERS.xml](http://www.molex.com/molex/products/datasheet.jsp?part=active/0878320628_PCB_HEADERS.xml)

**Notes**

- To bypass the STO protection, add 3 x 2 mm pitch jumpers ([Sullins Connector SPN02SVEN-RC<sup>43</sup>](#)) between pins 1-2, 3-4, 5-6.
- See [Safe Torque Off \(STO\)](#) (see page 112) for operation information.



**Do not confuse with RS485 connector**

RS485 and STO have the same number of pins. Take due precautions not to connect them incorrectly.

**Mating**

**Description** 2.00mm Pitch, Milli-Grid™ Receptacle Housing, 6 Circuits, with Center Locking Ramp and Side Polarization Keys.

**Image**



**Part number** Molex 51110-0656

**Distributor code** Mouser [538-51110-0656<sup>44</sup>](#)

**Notes**

- Triangle on the bottom left indicates pin 1.
- See [Milli-Grid connectors mating](#) (see page 25) for further information about crimping terminals and cables.

<sup>43</sup> [http://www.sullinscorp.com/drawings/273\\_SVEN\\_11502.pdf](http://www.sullinscorp.com/drawings/273_SVEN_11502.pdf)

<sup>44</sup> <http://www.mouser.es/ProductDetail/Molex/51110-1056/?qs=%2fha2pyFaduiMjkwWmWuOZy0mFhuCLeDSv3wJ9%2f1J325nRN%2fRFKKgQ%3d%3dhttp://www.mouser.es/ProductDetail/Molex/51110-0656/?qs=%2fha2pyFaduiRYgZFCN39oj096EslCEd%252b3Lq%2fKp7HoH6mu4TOf65WQ%3d%3d>

**5.10 EtherCAT connectors (TRI-x/48-E-C)**

**P9-P10 Connectors**

ECAT port 1 (P9)

ECAT port 0 (P10)

Network GND M2.5 screw connector

2x ECAT connectors are 4 pin 2 row Milli-Grid™ 2 mm pitch header. [Molex 878320406](http://www.molex.com/molex/products/datasheet.jsp?part=active/0878320406_PCB_HEADERS.xml)<sup>45</sup>

The network GND spacer is a SMD mounted female spacer. [Wurth Electronics 9774015151R](http://katalog.we-online.de/en/em/SMSI_SMT_STEEL_SPACER_M2_5_THREAD_INTERNAL)<sup>46</sup>

Pin (port 0 and port 1 have identical pinouts)	Signal	Function
M2.5 female screw	NETWORK_GND	<b>Optional</b> connection for the EtherCAT cable shield / system enclosure. Use ring terminals with short cables if needed.  The 75 Ω EtherCAT termination common is connected to this terminal (NETWORK_GND) with a 1 nF 2 kV capacitor and 1 MΩ resistor in series.
1	TX_D+	Transmit Data+ line. Colour typ: White - <b>Orange</b>
2	RX_D+	Receive Data+ line. Colour typ: White - <b>Green</b>

<sup>45</sup> [http://www.molex.com/molex/products/datasheet.jsp?part=active/0878320406\\_PCB\\_HEADERS.xml](http://www.molex.com/molex/products/datasheet.jsp?part=active/0878320406_PCB_HEADERS.xml)

<sup>46</sup> [http://katalog.we-online.de/en/em/SMSI\\_SMT\\_STEEL\\_SPACER\\_M2\\_5\\_THREAD\\_INTERNAL](http://katalog.we-online.de/en/em/SMSI_SMT_STEEL_SPACER_M2_5_THREAD_INTERNAL)

3	TX_D-	Transmit Data- line. Colour typ: <b>Orange</b>
4	RX_D-	Receive Data- line. Colour typ: <b>Green</b>

**Notes**

- Use ring terminal to connect the cable shield or to the system enclosure if needed.
- The EtherCAT is fully isolated, **magnetics are included** on board of TRI-x/48-E-C. The TRI-x/48-E-P (Triton **core**, with pin headers) has the PHY interface accessible without isolation.
- Please see [Communications \(see page 104\)](#) page for further information

 NETWORK\_GND must NOT be confused with PE or GND. And should be preferably be connected to the system chassis / enclosure or PE.

**Mating**

Description	2.00mm Pitch, Milli-Grid™ Receptacle Housing, 4 Circuits, with Center Locking Ramp and Side Polarization Keys.
Image	
Part number	Molex 51110-0456
Distributor code	Mouser <a href="#">538-51110-0456</a> <sup>47</sup>

**Notes**

- Triangle on the bottom left indicates pin 1.
- See [Milli-Grid connectors mating \(see page 25\)](#) for further information about crimping terminals and cables.

**NETWORK\_GND mating - ring terminal**

Description	Avikrimp™ Metric Ring Terminal for Stud Size 4 (M2.5), Insulated Barrel
-------------	---

<sup>47</sup> <http://www.mouser.es/ProductDetail/Molex/51110-0456/?qs=%2fha2pyFaduhDrb84c5tZzdYvAWKCi47fbly5v2d7RKlnAI%252bDogg28w%3d%3d>

Image	
Part number	MOLEX 19324-0001
Distributor codes	Mouser <a href="#">538-19324-0001</a> <sup>48</sup> Digi-Key <a href="#">WM9605-ND</a> <sup>49</sup>

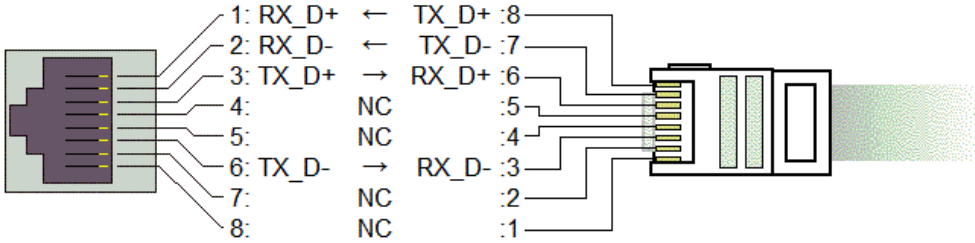
RJ-45 Connectors	
Description	As a standard, EtherCAT uses the same physical layer and RJ-45 connectors as Ethernet. This is a suggested wall connector, others might be valid too.
Image	
Pinout (10/100 Base-T)	
Part number	TE Connectivity 1-1546410-1
Distributor codes	Digi-Key <a href="#">A34356-ND</a> <sup>50</sup> Mouser <a href="#">571-1-1546410-1</a> <sup>51</sup> Farnell <a href="#">1769889</a> <sup>52</sup>

<sup>48</sup> <http://www.mouser.es/ProductDetail/Molex/19324-0001/?qs=sGAEpiMZZMvz8LftK4jeroIRoFT0AvEyhqa4DPqT%2f3M%3d>

<sup>49</sup> <http://www.digikey.es/product-detail/es/molex-llc/0193240001/WM9605-ND/3884466>

<sup>50</sup> <http://www.digikey.es/products/es?keywords=571-1-1546410-1>

<sup>51</sup> <http://www.mouser.es/ProductDetail/TE-Connectivity/1-1546410-1/?qs=%2fha2pyFaduhFoZ0HxTyc4oCk7KK2TdZ6VG01FtLhXyZ%2fR2tu2EE6vw%3d%3d>

<sup>52</sup> <http://es.farnell.com/te-connectivity/1-1546410-1/rj45-ethernet-connector-jack-8/dp/1769889?ost=1-1546410-1&selectedCategoryId=&categoryNameResp=Todas%2Blas%2Bcategor%25C3%25ADas&searchView=table&isrfrnonsku=false>

**5.11 CAN connectors (TRI-x/48-C-C)**

**P9-P10 Connectors**

Jumper position to enable CAN bus termination.

CAN IN and CAN OUT pins 2, 3 and 4 are connected pin-to-pin. They are called "IN" and "OUT" for wiring purposes only. The only difference is that CAN Out includes a pin (1) for termination.

2x CAN connectors are 4 pin 2 row Milli-Grid™ 2 mm pitch header. [Molex 878320406](http://www.molex.com/molex/products/datasheet.jsp?part=active/0878320406)<sup>53</sup>

Pin	Signal	Function
<b>CAN OUT (P9)</b>		
1	CAN_TERM	120 Ω termination resistor connected between this pin and pin 4 (CAN_H)
2	CAN_GND	CAN ground
3	CAN_L	CAN bus line dominant low
4	CAN_H	CAN bus line dominant high
<b>CAN IN (P10)</b>		
1	NC	Not connected

<sup>53</sup> [http://www.molex.com/molex/products/datasheet.jsp?part=active/0878320406\\_PCB\\_HEADERS.xml](http://www.molex.com/molex/products/datasheet.jsp?part=active/0878320406_PCB_HEADERS.xml)

2	CAN_GND	CAN ground
3	CAN_L	CAN bus line dominant low
4	CAN_H	CAN bus line dominant high

**Notes**

- The CAN bus must always be terminated at the ends with 120Ω. This termination is included on Triton.
- Enable the CAN termination by placing a 2 mm pitch jumper between pins 1 and 3 of connector P9 (CAN OUT). [Sullins Connector SPN02SVEN-RC](#)<sup>54</sup>. The termination jumper should only be placed on P9, using it P10 will have no effect.
- Please see [Communications](#) (see page 104) page for further information

**Mating**

Description	2.00mm Pitch, Milli-Grid™ Receptacle Housing, 4 Circuits, with Center Locking Ramp and Side Polarization Keys.
Image	
Part number	Molex 51110-0456
Distributor code	Mouser <a href="#">538-51110-0456</a> <sup>55</sup>

**Notes**

- Triangle on the bottom left indicates pin 1.
- See [Milli-Grid connectors mating](#) (see page 25) for further information about crimping terminals and cables.

<sup>54</sup> [http://www.sullinscorp.com/drawings/273\\_SVEN\\_11502.pdf](http://www.sullinscorp.com/drawings/273_SVEN_11502.pdf)

<sup>55</sup> <http://www.mouser.es/ProductDetail/Molex/51110-0456/?qs=%2fha2pyFaduhDrb84c5tZzdYvAWKCi47fbly5v2d7RKlnAI%252bDogg28w%3d%3d>

## 6 Signalling LEDs

Triton Go Servo Drive provides information through 6 signalling LEDs:

- Supply and operation: 2 LEDs (one of them bi-color) next to the Supply, shunt and motor connector.
- CANopen communication: 2 LEDs next to the CAN/EtherCAT connectors (shared with EtherCAT option).
- EtherCAT communication: 4 LEDs next to the CAN/EtherCAT connectors (2 LEDs shared with CAN option).

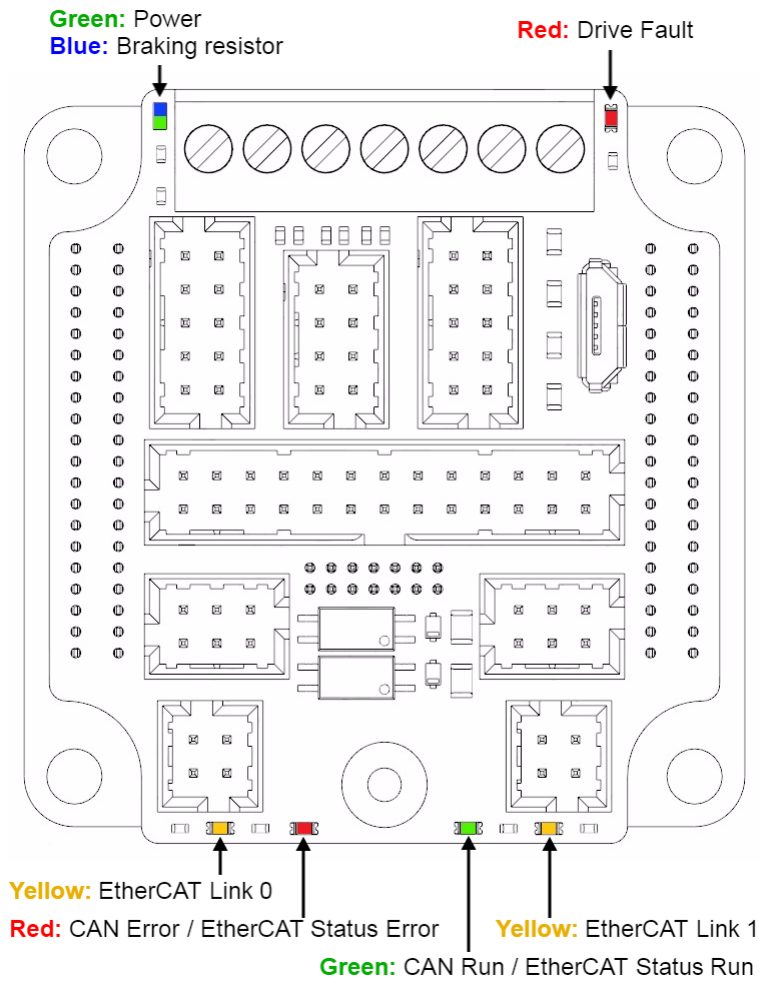

### 6.1 Power and operation signalling LEDs

Two LEDs situated next to the Supply, shunt and motor connector indicate the supply and operation status. Note that Power LED and Braking resistor LED are packed into a single green/blue bi-color LED.

LED	Colour	Meaning
POWER	<b>Green</b>	LED is on when internal power supply is working.



LED	Colour	Meaning
SHUNT	Blue	<p>LED is turned on when the supply voltage is greater than the maximum voltage configured by the user.</p> <div style="border: 1px solid #ffc107; padding: 5px; margin-top: 10px;"> <p> <b>Configuration required</b></p> <p>This signal will only work if the braking resistor output is configured as active.</p> </div>
FAULT	Red	<p>LED is on when an error event has occurred and the drive is trapped in the <b>Fault state</b>. Find more about the Fault state in the <a href="#">E-Core documentation</a><sup>56</sup> page.</p>

### 6.2 CAN signalling LEDs (only TRI-x/48-C-C)

Two LEDs besides the CAN/EtherCAT connectors provide information about the CANopen communication status, according to [CiA 303-3 recommendations](#)<sup>57</sup>. The red LED is **ERROR LED** and green one is **RUN LED**.

ERROR LED indicates the status of the CAN physical layer and errors due to missed CAN messages (sync, guard or heartbeat). Next table the meaning of the ERROR LED states:

ERROR LED state*	Concept	Description
Off	No error	Device is in working condition.
Single flash	Warning limit reached	At least one of the error counters of the CAN controller has reached or exceeded the warning level (too many error frames).
Double flash	Error control event	A guard event (NMT-slave or NMT-master) or a heartbeat event (heartbeat consumer) has occurred.
Triple flash	Sync error	The sync message has not been received within the configured communication cycle period time out.
On	Bus off	The CAN controller is bus off.

RUN LED indicates the status of the CANopen network state machine. Next table shows the meaning of the RUN LED states:

<sup>56</sup> <http://doc.ingeniamc.com/display/EMCL/Error+management>

<sup>57</sup> <http://www.can-cia.org/>

RUN LED state*	Concept	Description
Off	Off	The device is switched off
Blinking	Pre-operational	The device is in state PREOPERATIONAL
Single flash	Stopped	The device is in state STOPPED
On	Operational	The device is in state OPERATIONAL

\*See a detailed description of the states in the next table:

* Possible LED states	Description
ON	The LED is always on
OFF	The LED is always off
Single flash	One short flash (~200 ms) followed by a long off phase (~1000 ms)
Double flash	Sequence of 2 short flashes (~200 ms), separated by an off phase (~200 ms). The sequence is finished by a long off phase (~1000 ms)
Triple flash	Sequence of 3 short flashes (~200 ms), separated by an off phase (~200 ms). The sequence is finished by a long off phase (~1000 ms)
Blinking	On and off with a frequency of ~2.5 Hz: ON for ~200 ms followed by off for ~200 ms.

Note that the specified timings can vary in up to ±20%.

**i External LEDs**

The user can connect external LEDs by means of LED\_RUN\_K and LED\_ERR\_K pins in the **I/O & LEDs connector** (see page 23). These LEDs shall behave exactly the same as described above.

### 6.3 EtherCAT signalling LEDs (only TRI-x/48-E-C)

Four LEDs below the CAN/EtherCAT connectors provide information regarding communication status according to EtherCAT<sup>58</sup> specification.

<sup>58</sup> <https://www.ethercat.org/default.htm>

The EtherCAT green and red LEDs (shared with CAN communication) indicate the EtherCAT state machine status. The green LED is the **RUN LED**, and the red LED is the **ERROR LED**. Next table shows their states meaning:

<b>RUN LED state</b>	EtherCAT slave status	<b>ERROR LED state</b>	EtherCAT slave status
Off	INIT	Off	No error
Blinking	PRE-OPERATIONAL	Blinking	Invalid configuration
Single Flash	SAFE-OPERATIONAL	Single flash	Local error
On	OPERATIONAL	Double flash	Watchdog timeout
		On	Application controller failure

For high severity errors inside the Triton Go Servo Drive, a special LED state has been developed:

Status	Signalling	<b>RUN LED state</b>	<b>ERROR LED state</b>
<b>Internal error</b>	Interleaved blink	Blinking (Initial status: OFF)	Blinking (Initial status: ON)

The two yellow LEDs at the sides are the **LINK 0** and **LINK 1** LEDs. The **LINK LEDs** indicates the state of the EtherCAT physical link activity:

<b>LINK LED state</b>	Slave State
Off	Port closed
Flickering	Port opened (activity on port)
On	Port opened (no activity on port)

**i External LEDs**

The user can connect external LEDs by means of LED\_RUN\_K, LED\_ERR\_K, LED\_LINK1\_K and LED\_LINK0\_K pins in the **I/O & LEDs connector** (see page 23). These LEDs shall behave exactly the same as described above.

## 7 Wiring and Connections

Proper wiring, and **especially grounding and shielding**, are essential for ensuring safe, immune and optimal servo performance of Triton Go Servo Drive. Next pages show detailed connection recommendation as well as technical details of each interface.

- [Protective earth](#) (see page 52)
- [Power supply](#) (see page 55)
- [Motor and shunt braking resistor](#) (see page 59)
- [Feedback connections](#) (see page 64)
- [I/O connections](#) (see page 79)
- [Command sources](#) (see page 96)
- [Communications](#) (see page 104)
- [Safe Torque Off \(STO\)](#) (see page 112)

### 7.1 Protective earth

**Connection of Triton Go Servo Drive and motor housing to Protective Earth (PE)** is required for **safety reasons**. Electrical faults can electrically charge the housing of the motor or cabinet, increasing the risk of electrical shocks. A proper connection to PE derives the charge to Earth, activating the installation safety systems (differential protections) and protecting the users.

Moreover, a proper connection to PE prevents many of the noise problems that occur operating a servo drive.

#### Reducing EMI susceptibility

**Connecting the drive PE terminals and cold plate screws to your system Earth and to the motor housing solves many noise and EMI problems.** The PE drive terminals are decoupled to power ground through a safety capacitor. This provides a low impedance preferential path for coupled common mode noises that otherwise would be coupled to sensitive electronics like the encoders. A good **grounding of the drive to the earth of the power supply** is also essential for a EMI reduction.

Triton Go Servo Drive provides the following earth/ground connection points, which are internally connected and decoupled to power ground and power supply:

- PE terminal in the Supply, shunt and motor connector.
- PE terminal in the Halls, motor temperature and analog feedback connector.
- PE terminal in the Absolute encoder connector.
- PE terminal in the Incremental and Sin-Cos encoder connector.
- PE terminal in the I/O and LEDs connector.
- PE terminal in the RS485 connector.
- Cold plate is connected to PE.

A diagram of the recommended Earth wiring is shown below.

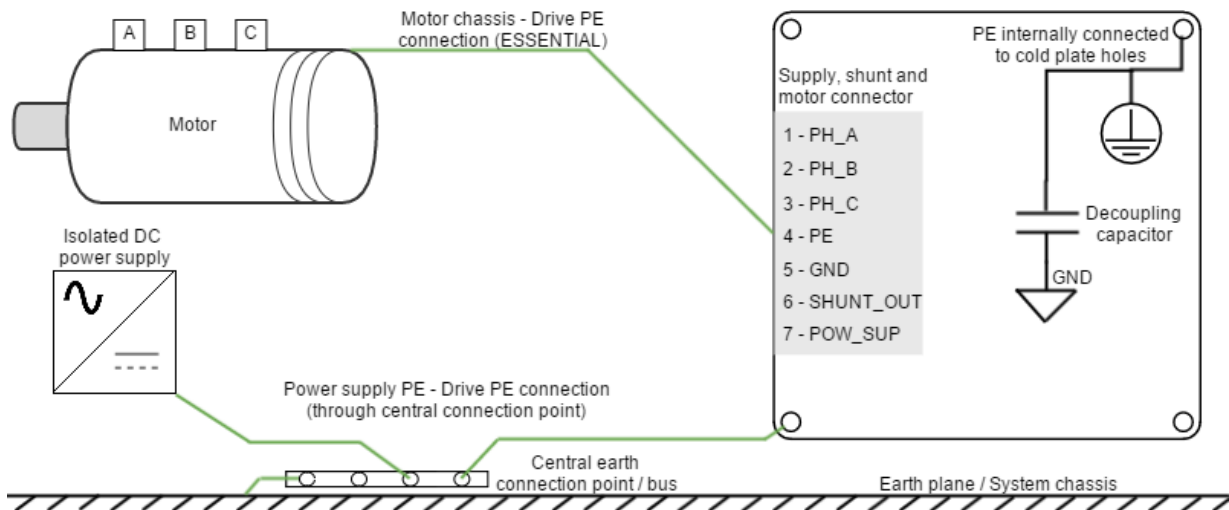

**i Earth plane reference**

While some systems will not have a "real Earth" connection, use your **machine chassis**, the metallic structure of the device or a good grounding conductive plane as your reference earth.

Some considerations for a proper earth connection are detailed next:

- Switching noise can be coupled to the earth through the housing of the motor. This high-frequency noise creates common mode current loop between drive and motor. Although the motor housing is connected to earth through the system chassis, its electrical connection may have a relatively high impedance and present a big loop. For this reason is essential to reduce the common mode current return path impedance and its loop area.
  - For reducing the return path impedance, **motor frame should be directly wired** to drive PE terminals.
  - PE wiring should be as close as possible to power cables, reducing current loop.
- Power supply is another source of switching noise. The neutral of the grid transformer or the housing of our power supply may also be connected to earth. For reducing noise and EMI, similar considerations should be taken.
  - **Directly wire power supply PE to drive PE.**
  - PE wiring should be as close as possible to power supply cables.
- In order to avoid ground loops, it is a good practice to have a **central earth connection point (or bus)** for all the electronics of the same bench. If multiple drives are supplied from the same power supply or supply PE to drive PE connection is not practical (not enough connection terminals) connect all PE terminals in a central connection bus.
- Whenever possible, **mount the Ingenia drive on a metallic conductive surface** connected to earth. Use **good quality plated screws** that won't oxidize or lose conductivity during the expected lifetime. Note that the PE terminal is internally connected with the Triton Go Servo Drive standoffs.
- For achieving low impedance connections, use wires that are **short, thick, multistrand cables** or preferably **conductive planes**. PE wire section should be, at least, the same as power supply cables. Always **minimize PE connection length**.

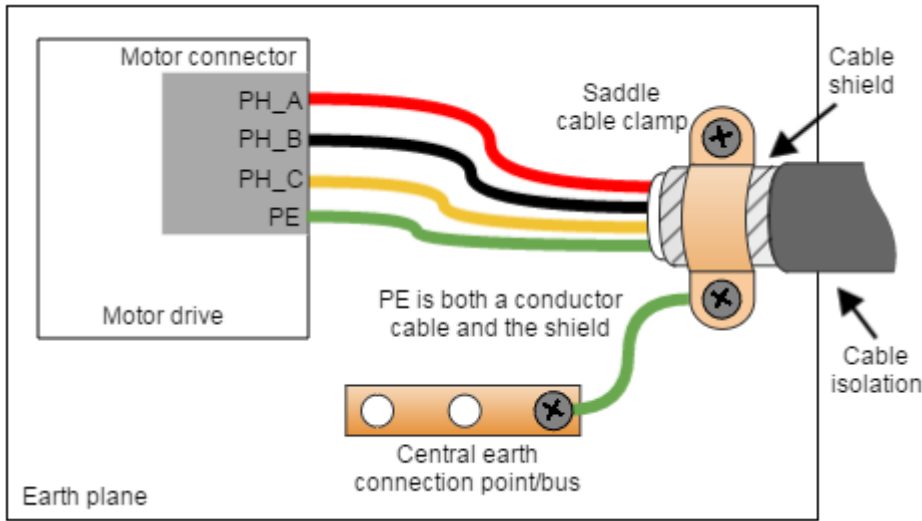

For an even better EMI immunity, **use shielded or armored cables** with isolating jacket, connecting the shield to PE with a cable clamp.



If a simplified wiring is required, the following shielding priority can be applied:

1. Shield the motor cables, which are the main high-frequency noise source.
2. Shield the feedback signals, which are sensitive signals usually coming from the motor housing.
3. Shield I/O signals and communication cables.

The **clamp has to be selected according to the shielded cable diameter, ensuring a good support and connection** between the cable shield and the clamp. Following examples are only suggested for conceptual purpose:

Description	Image	Part number
Cable Clamp, P-Type Silver Fastener 0.625" (15.88 mm)		Keystone Electronics 8107
Cable Clamp, P-Type Silver Fastener 0.187" (4.75 mm)		Keystone Electronics 8100
Cable Clamp, Saddle Type Stainless Steel 20 mm		RS Pro 471-1300

## 7.2 Power supply

The Triton Go Servo Drive is supplied from the Supply, shunt and motor connector, using the same terminal for logic and power supply ( $8 V_{DC}$  to  $48 V_{DC}$ ). An internal DC/DC converter provides circuits with appropriate voltages as well as regulated 5 V and 3.3 V output voltages to supply feedback sensors and I/O.

The Triton Go can be powered from USB for configuration purposes without the need of an external power supply. An internal switch automatically chooses the power source prioritizing the external supply. Please note that several functionalities will not be available when powered from USB.

### **USB Powered Triton**

When the Triton Go is powered **from USB, only basic configuration and programming options are available**. The drive is not capable of driving a motor or sensing a feedback input due to USB power limitations.

### **Disconnection recommendations**

There are no critical instructions for disconnecting the Triton Go. Just some recommendations:

- The board could be hot during < 1 min after disconnection.
- Preferably do not disconnect the supply while having a motor in motion.
- If working with Motion Lab with USB connection, preferably disconnect the drive from the application before disconnecting. This prevents COM port corruption.

### 7.2.1 Power supply requirements



The choice of a power supply is mainly determined by voltage and current ratings of the power supply. Main requirements of the Triton Go power supply are:

- The **voltage** should be the targeted for the motor. This means up to **48 V** for all Triton Go part numbers (**TRI-x/48-y-C**). Make sure that the voltage rating of the power supply does not exceed the voltage rating of the motor, otherwise it could be damaged.
- The **current** should be the one able to provide the phase peak current of the application. This means up to **1 A** for the **TRI-1/48-y-C**, up to **5 A** for the **TRI-4/48-y-C** and up to **8.5 A** for the **TRI-7/48-y-C**. Make sure that the current rating for the power supply is at least as high as the motor.
- The voltage and current range can be decreased due to the motor requirements.

**Further information on how to dimension a power supply for the Ingenia drives can be found [here](#)<sup>59</sup>.**

Following are shown different power supply examples:

<sup>59</sup> <http://doc.ingeniamc.com/display/KB/How+to+dimension+a+power+supply+for+an+Ingenia+drive>

Manufa cturer	Part Number	Rated Voltage (V)	Rated Current (A)	Image	Description
XP Power	ECE60US 48	48	1.25		Switching closed frame power supply recommended for TRI-1/48-y-C, 60 W
TDK Lambda	PFE300S A48/T	48	6.3		Switching closed frame power supply recommended for TRI-4/48-y-C, 300 W
TDK Lambda	PFE500 F48	48	10.5		Switching closed frame power supply recommended for TRI-7/48-y-C, 500 W

### 7.2.2 Power supply connection

Triton Go logic and power supply are provided through the same terminal. All Triton Go versions support an input voltage of +9 V to +48 V.

 **Twisted cables**

Twisted power supply cables are preferred to reduce electromagnetic emissions and increase immunity.

The following picture show the Triton Go supply wiring diagram.

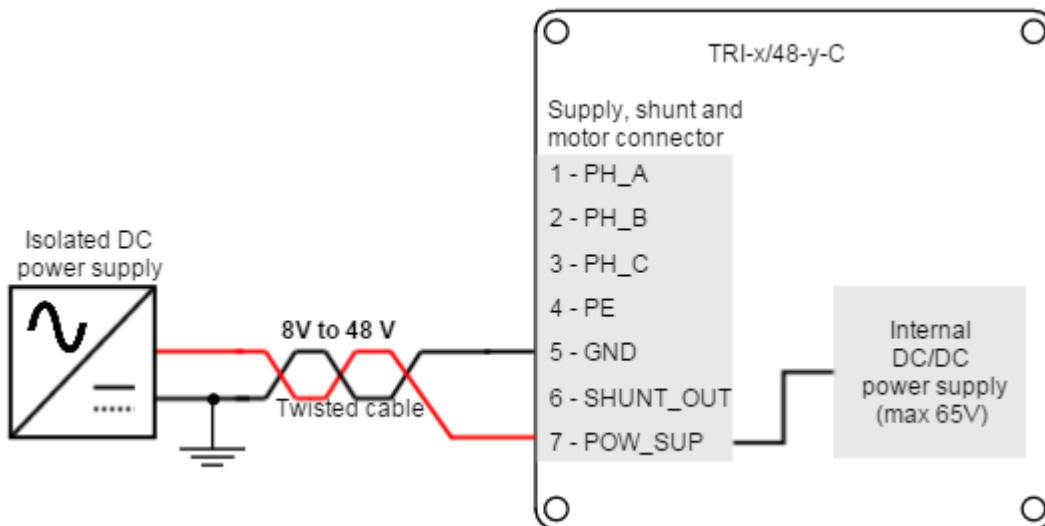



**✔ Isolated power supplies**

For safety reasons, it is important to use **power supplies with full galvanic isolation**.

**7.2.3 Battery supply connection**

Next figure shows a simplified wiring diagram for the Triton Go Servo Drive supplied from a battery.

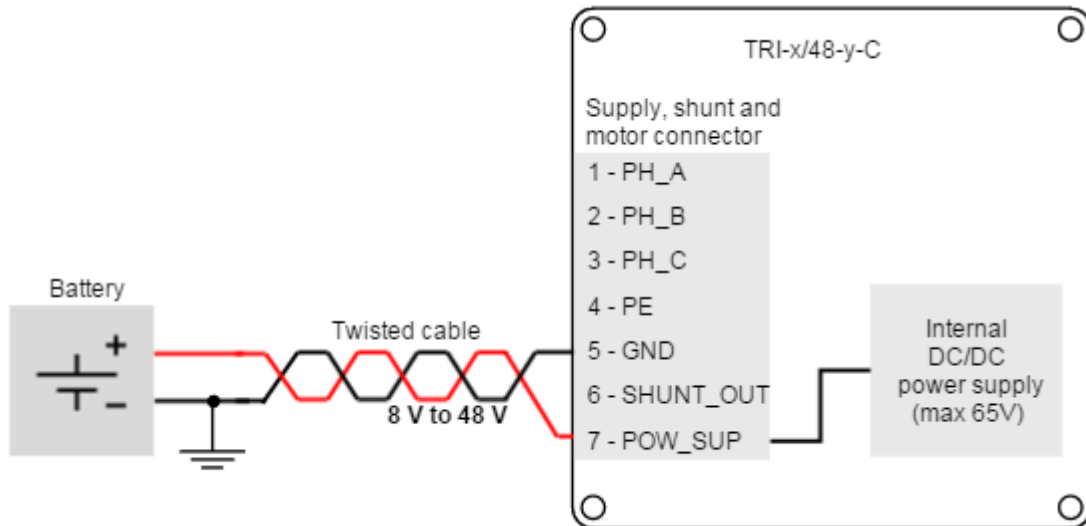

**⚠ Motor braking current**

Motor braking can cause reverse current sense and charge the battery. Always ensure that the battery can accept this charge current which will be within the Triton Go current ratings.

**7.2.4 Connection of multiple drives with the same power supply**

When **different servo drives are connected to the same power supply**, connect them in **star topology** for reducing cable impedance and common mode coupled noise. That is, connect each drive to the common supply using separate wires for positive and return.

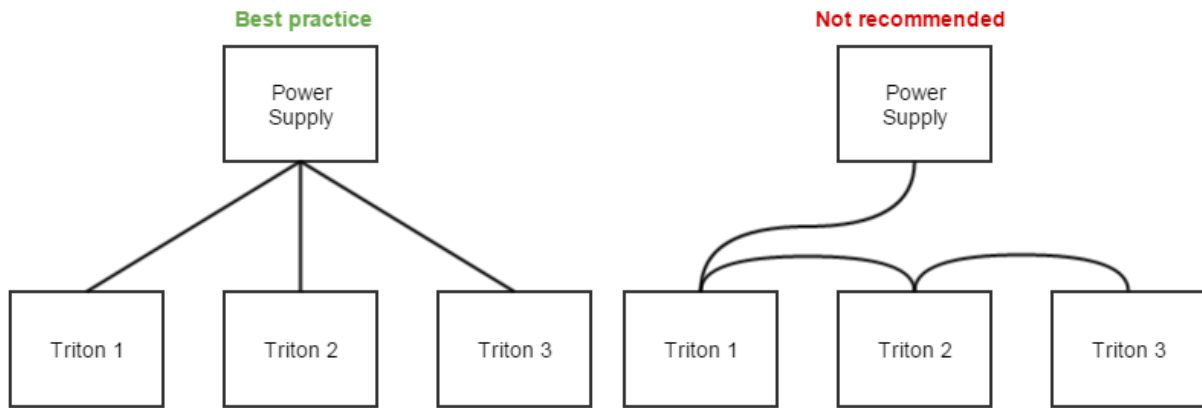

### 7.2.5 Power supply wiring recommendations

#### Wire section

The minimum wire section is determined by the current consumption and the allowed voltage drop across the conductor. It is preferred to use **wide section stranded wires** to reduce impedance, power losses and ease the assembly. Insulator size should not exceed 3.5 mm (connector pitch). Following table indicates recommended wire sections:

Connection	Minimum wire size	Maximum wire size
Stranded wire (preferred)	0.5 mm <sup>2</sup> (20 AWG)	1.5 mm <sup>2</sup> (16 AWG)
Solid wire	0.5 mm <sup>2</sup> (20 AWG)	1.5 mm <sup>2</sup> (16 AWG)

#### Wire ferrules

For **low power applications**, it is recommended to use wire ferrules to prevent cable damage or wrong contacts. For **higher power applications, direct cable connection is recommended**, since it provides lower contact resistance. Due to the connector's size, the maximum allowed ferrule size is 0.5 mm<sup>2</sup>. Ensure the insulator does not exceed 3.5 mm (connector pitch). Following table indicates recommended wire ferrules for the Triton Go Servo Drive:

Manufacturer	Part number	Image	Description
Phoenix Contact	3201369 <sup>60</sup>		8 mm pin length, 0.5 mm <sup>2</sup> (20 AWG)

<sup>60</sup> <http://www.digikey.es/product-detail/en/3200881/277-5453-ND/349955>

TE Connectivity	966067-1 <sup>61</sup>		6 mm pin length, 0.5 mm <sup>2</sup> (20 AWG)
-----------------	------------------------	---	--

### Wire length

- The distance between the Triton Go Servo Drive and the power supply **should be minimized when possible**. Short cables are preferred since they reduce power losses as well as electromagnetic emissions and immunity.
- For best immunity use twisted and shielded 2-wire cables for the DC power supply. This becomes crucial in long cable applications.
- Avoid running supply wires in parallel with other wires for long distances, especially feedback and signal wires.

## 7.3 Motor and shunt braking resistor

### 7.3.1 AC and DC brushless motors

Brushless motors should be connected to phase A, B and C terminals. Note that some manufacturers may use different phase name conventions (see Table below).

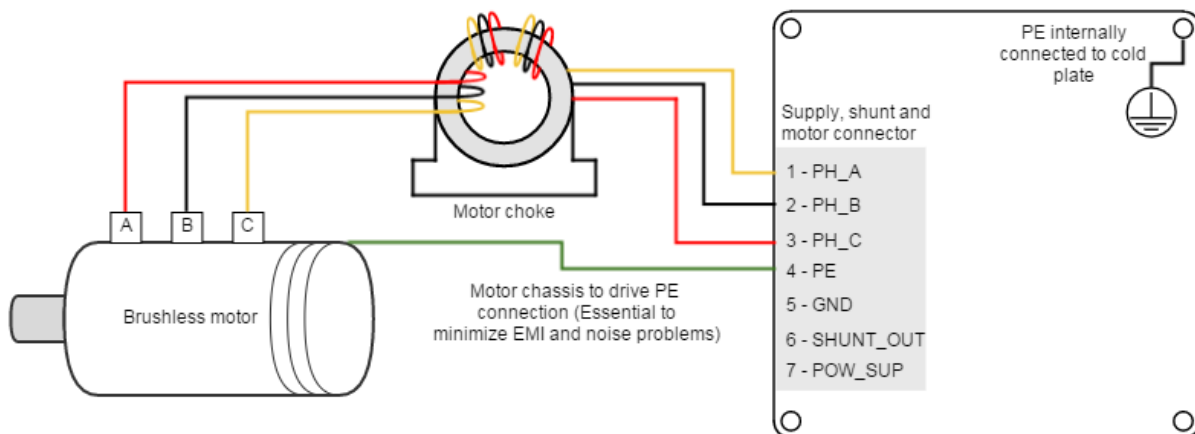

Phase name	Alphabetic	Numeric	UVW
PH_A	A	1	U
PH_B	B	2	V
PH_C	C	3	W

<sup>61</sup> <http://www.digikey.es/product-detail/en/966067-1/A114629-ND/1152396>

**✓ Common-mode choke**

In order to minimize EMI that can affect sensitive signals, the use of a **motor choke** is recommended. The objective of the motor choke is to **block the common mode current** to the motor and cables. While using a separate choke for each phase could also work, the EMI reduction would be much lower than passing all the phases through the same choke.

**i Proper three-phase motor choke wiring**

In order to minimize the capacitive coupling of the motor wires, and therefore cancelling the effect of the common mode rejection effect, the choke has to be properly wired.

- An excessive number of turns causes a high capacitive coupling. Only 2 or 3 turns per motor phase are recommended.
- For reducing the coupling between phases, space the phases 120° apart. **Start each phase wire in the same rotating direction**, wrapping all phases clockwise or anticlockwise. This will add the common mode flux and increase its impedance.

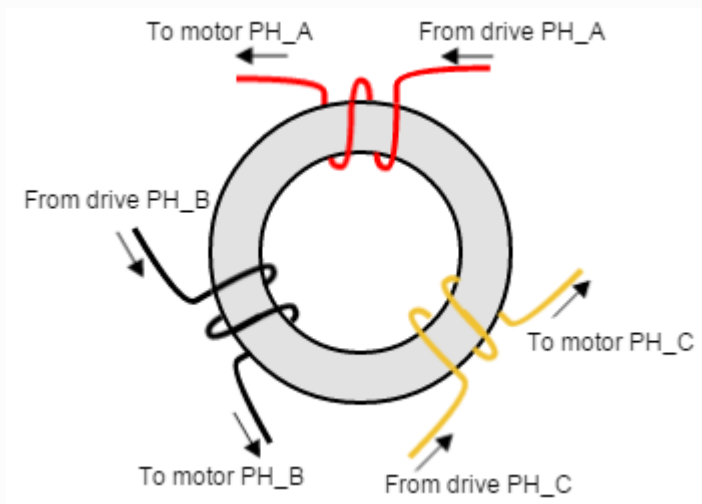

**7.3.2 DC motors and voice coils actuators**

DC motors and voice coil actuators are connected to phase A and phase B terminals. Phase C terminal is left unconnected.

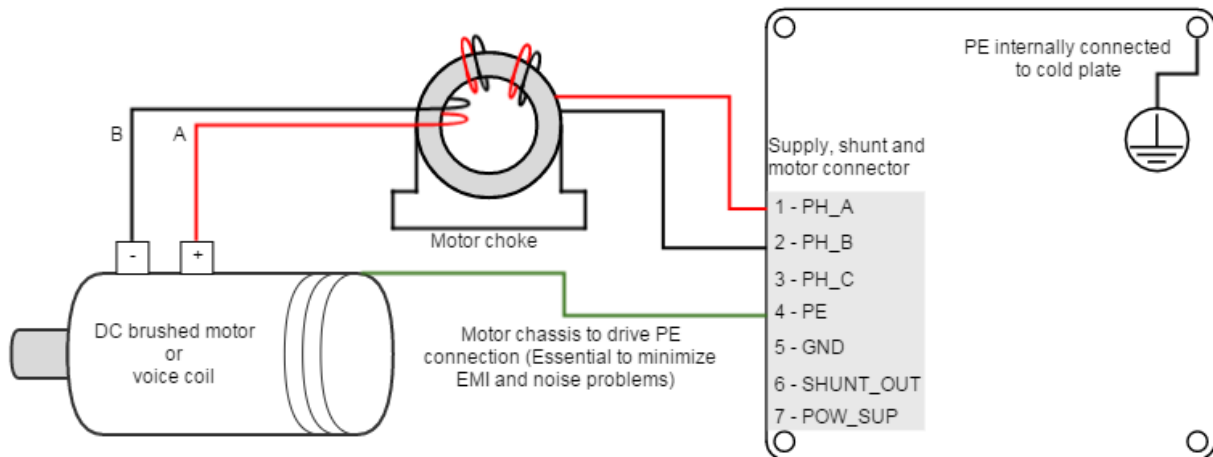

**✓ Common-mode choke**

In order to minimize EMI that can affect sensitive signals, the use of a **motor choke** is recommended. The objective of the motor choke is to **block the common mode current** to the motor and cables. While using a separate choke for each phase could also work, the EMI reduction would be much lower than passing all the phases through the same choke.

**i Proper DC motor choke wiring**

In order to minimize the capacitive coupling of the motor wires, and therefore cancelling the effect of the common mode rejection effect, the choke has to be properly wired.

- An excessive number of turns causes a high capacitive coupling. Only 2 or 3 turns per motor phase are recommended.
- For reducing the coupling between positive and negative, space them 180° apart. **Start positive and negative wire in the same rotating direction**, wrapping both phases clockwise or anticlockwise. This will add the common mode flux and increase its impedance.

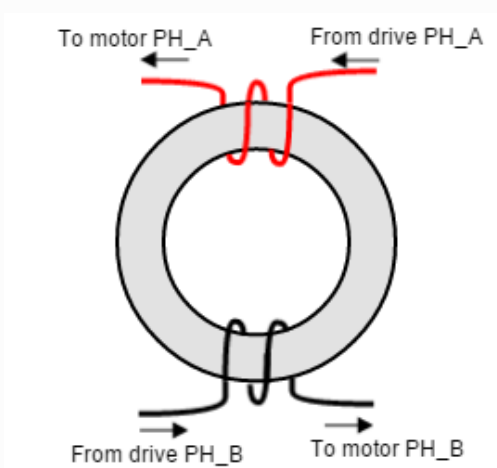

### 7.3.3 Motor wiring recommendations

#### Wire section

The minimum wire section is determined by the motor current. It is preferred to use **wide section stranded wires** to reduce impedance, power losses and ease the assembly. Insulator size should not exceed 5 mm (connector pitch). Following table indicates recommended section for the Triton Go Servo Drive:

Connection	Minimum wire size	Maximum wire size
Stranded wire (preferred)	0.5 mm <sup>2</sup> (20 AWG)	1.5 mm <sup>2</sup> (16 AWG)
Solid wire	0.5 mm <sup>2</sup> (20 AWG)	1.5 mm <sup>2</sup> (16 AWG)

#### Wire ferrules

For **low power applications**, it is recommended to use wire ferrules to prevent cable damage or wrong contacts. For **higher power applications, direct cable connection is recommended**, since it provides lower contact resistance. Due to the connector's size, the maximum allowed ferrule size is 0.5 mm<sup>2</sup>. Ensure the insulator does not exceed 3.5 mm (connector pitch). Following table indicates recommended wire ferrules for the Triton Go Servo Drive:

Manufacturer	Part number	Image	Description
WAGO	<a href="http://www.wagocatalog.com/okv3/index.asp?lid=5&amp;cid=51&amp;strBestNrID=2160206">216-201</a> <sup>62</sup>		0.5 mm <sup>2</sup> (20 AWG)
WAGO	<a href="http://www.wagocatalog.com/okv3/index.asp?lid=5&amp;cid=51&amp;strBestNrID=2160224">216-224</a> <sup>63</sup>		1.5 mm <sup>2</sup> (16 AWG)

#### Motor choke

In applications where electromagnetic compatibility is a concern or that must comply with the EMC standards, the use of an external common mode choke is necessary. Some choke wiring recommendations are:

- Place the choke as close to the drive as possible.
- Make sure the chosen choke **does not saturate at the maximum operating phase current**. If this happens, the choke temperature would increase rapidly.
- **Only 2 or 3 turns of the motor cables** to the choke are recommended for best performance. Doing more than 3 turns reduces choke effectiveness, as capacitive coupling between wires would bypass the choke effect.
- **PE conductor should NOT** pass through the choke.
- Avoid contact of the toroid core with a grounding point.

<sup>62</sup> <http://www.wagocatalog.com/okv3/index.asp?lid=5&cid=51&strBestNrID=2160206>

<sup>63</sup> <http://www.wagocatalog.com/okv3/index.asp?lid=5&cid=51&strBestNrID=2160224>

Next table shows a choke that fits the Triton Go Servo Drive specifications and has a great performance at low frequencies.

Type	Manufacturer	Reference
Low frequency ferrite	Laird Technologies	<a href="#">LFB360230-300</a> <sup>64</sup>

### Wire length

- The distance between the Triton Go Servo Drive and the motor **should be minimized when possible**. Short cables are preferred since they reduce power losses as well as electromagnetic emissions and immunity.
- Avoid running motor wires in parallel with other wires for long distances, especially feedback and signal wires.
- The parasitic capacitance between motor wires should not exceed 10 nF. If very long cables (> 100 meters) are used, this value may be higher. In this case, add series inductors between the Triton Go outputs and the cable. The inductors must be magnetically shielded, and must be rated for the motor surge current. Typical values are around 100 µH.

### 7.3.4 Shunt braking resistor

While decelerating a motor (abrupt motion brakes or reversals), the mechanical energy is converted into electrical energy by the motor. This energy is regenerated into the power supply and could lead to an increase of the supply voltage. To absorb this energy the Triton Go **incorporates a shunt transistor to connect an external braking resistor**.

Wiring recommendations of the shunt braking resistor:

- The external braking resistor should be connected between SHUNT\_OUT and POW\_SUP terminals of the Triton Go Supply and shunt connector.
- It is strongly recommended to use an external fuse to limit the maximum power dissipation according to the chosen shunt resistor.
- **Wire section should be, at least, like the motor wires.**
- Shunt resistor connections should be as short as possible to reduce parasitic inductances.

#### **Shunt resistor calculation tool**

Additional information on shunt braking resistor sizing and a calculation tool can be found [here](#)<sup>65</sup>.

<sup>64</sup> <http://www.digikey.es/product-search/en?keywords=LFB360230-300>

<sup>65</sup> <http://doc.ingeniamc.com/display/KB/Dimensioning+a+Shunt+Resistor+for+Regenerative+Braking>

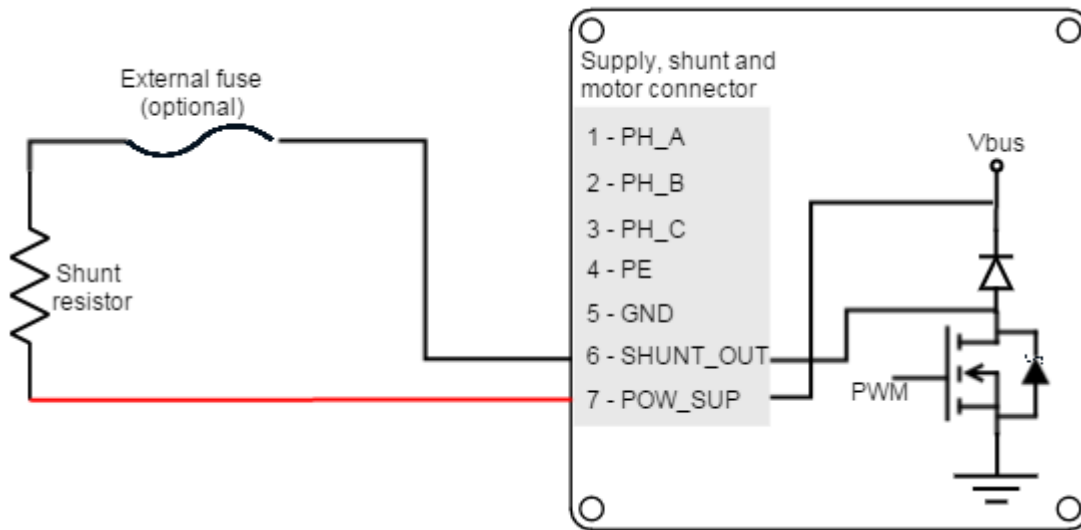

**Hot surfaces**

Be careful, shunt resistor may have hot surfaces during operation.

**Configuration of the shunt**

The shunt transistor can be configured using parameters in the register [0x2103 - Shunt configuration](#)<sup>66</sup>. When the supply voltage reaches the maximum voltage indicated in register [0x2101 - Drive bus voltage](#)<sup>67</sup>, the shunt transistor is activated.

As a recommendation, set the DC bus voltage limit above the maximum expected DC supply voltage + 5%.

**When using batteries set the DC bus voltage limit below the maximum charge voltage.** This will allow regenerative braking and protect the battery against overcharging.

**7.4 Feedback connections**

The Triton Go Servo Drive has multiple connectors (Halls, motor temperature and analog feedback connector, Absolute encoder connector and Incremental and Sin-Cos encoder connector) dedicated to the following feedback options:

- [Digital Halls](#) (see page 65)
- [Analog Halls](#) (see page 67)
- [Quad. Incremental encoder](#) (see page 69)
- [Analog encoder \(Sin-Cos encoder\)](#) (see page 72)
- [Absolute encoder](#) (see page 74)

Additional feedback connections can be found on [I/O connector](#) (see page 79):

<sup>66</sup> <http://doc.ingeniamc.com/display/EMCL/0x2103+-+Shunt+configuration>

<sup>67</sup> <http://doc.ingeniamc.com/display/EMCL/0x2101+-+Drive+bus+voltage>



- [PWM encoder](#) (see page 75)
- [Analog input for potentiometer](#) (see page 77)
- [Analog input for DC tachometer](#) (see page 77)

Triton also provides a 5V, 200 mA and 3.3V 50mA outputs for feedbacks supply. These outputs are overload and short circuit protected.

### 7.4.1 Digital Halls interface

The Hall sensors are Hall effect devices that are built into the motor to detect the position of the rotor magnetic field. Usually, motors include 3 hall sensors, spaced 60° or 120° apart. Using these 3 signals, the drive is capable to detect the position, direction and velocity of the rotor. Next figures show examples of digital halls signals.

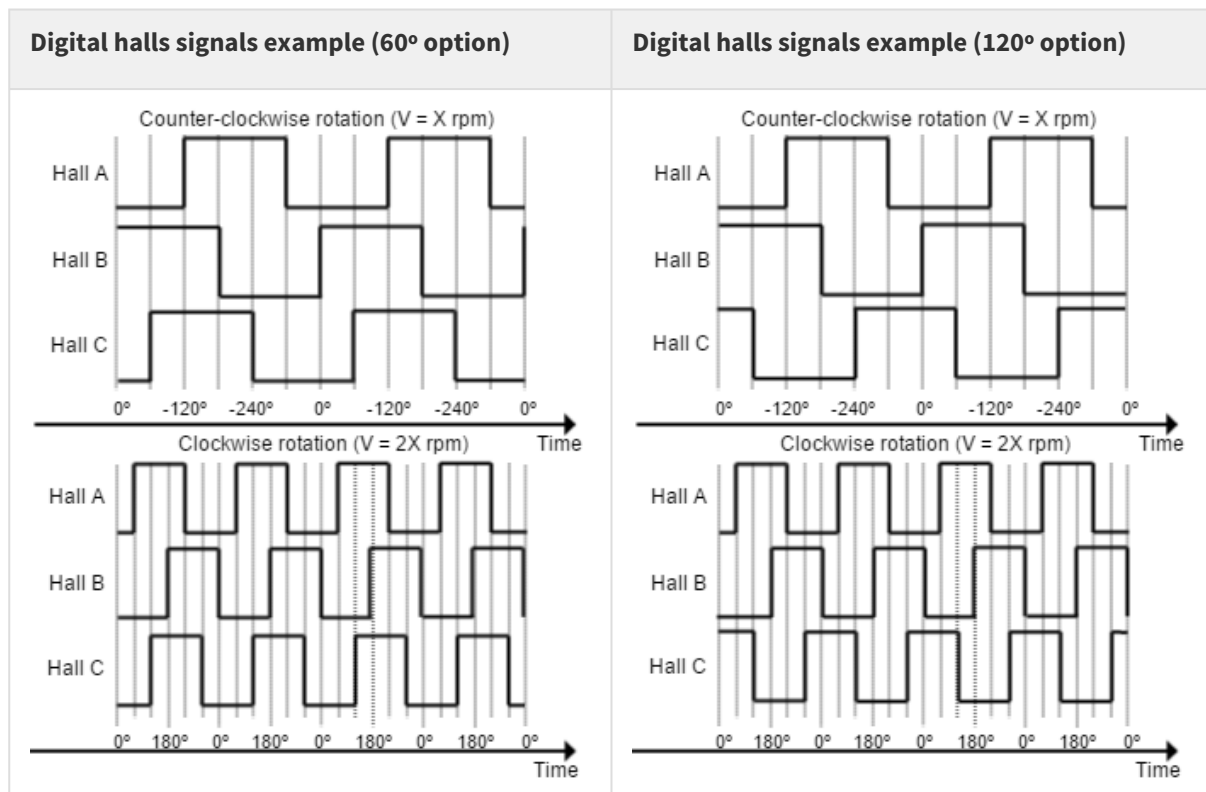

Digital halls can be used for commutation, position and velocity control. Resolution using these sensors is much lower than using encoders. **Triton Go can use single ended Hall sensors to drive the motor with trapezoidal commutation, but not with sinusoidal commutation.**

This interface accepts 0-5 V level input signals. Inputs are pulled up to 5 V, so industry standard open collector and logic output hall effect sensors can be connected. Next table summarizes digital halls inputs main features:

Specification	Value
Type of inputs	Non-isolated Single ended with pull-up and low pass filter ESD protected

Number of inputs	3
ESD capability	IEC 61000-4-2 (ESD) $\pm 30$ kV (air), $\pm 30$ kV (contact)
Voltage range	0 ~ 5 V
Maximum voltage range	-0.5 ~ 5.5 V
Maximum recommended working frequency	1 kHz
1st order filter cutting frequency (-3dB)	160 kHz
Sampling frequency	10 ksps
Type of sensors	Open collector Logic output Push-pull output
Pull-up resistor value	1 k $\Omega$ (The pull-up is activated only when the drive is configured to use digital hall sensors)

**i Digital and analog Halls**

Digital halls input pins are shared with [Analog Halls interface](#) (see page 67) pins.

The 1 k $\Omega$  pull-up resistors are disconnected when Analog-halls input is selected to prevent analog data corruption.

Next figure shows the circuit model of the digital Halls inputs.

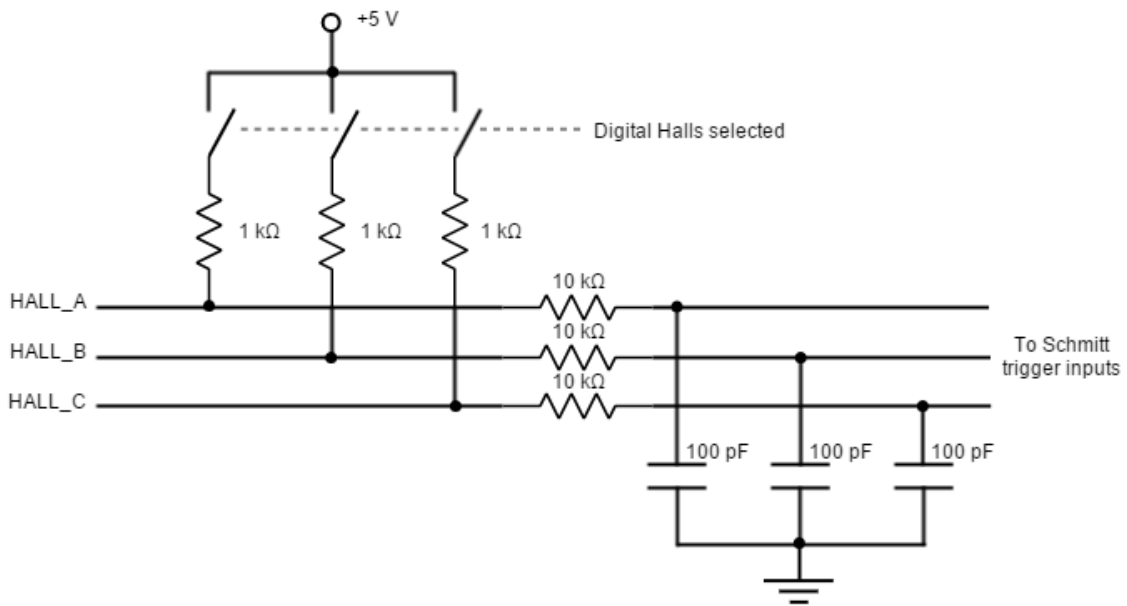

Next figure illustrates how to connect the digital halls to the Triton Go Servo Drive. Refer to [Feedback wiring recommendations](#) (see page 78) for more information about connections and wires.

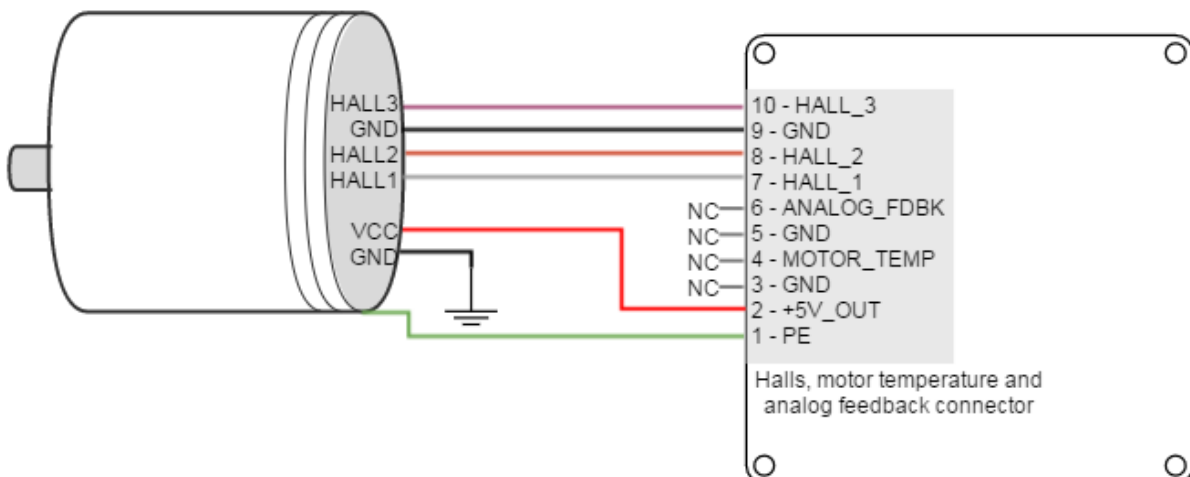

***i* Velocity control with Halls**

Due to inherent low resolution of motor mounted Hall sensors, they are not recommended for velocity feedback in low speed applications.

**7.4.2 Analog Halls interface**

The Triton Go Servo Drive can operate with analog Hall sensors (also known as linear halls) as feedback option. Signals provided by these sensors are typically 5 V peak-to-peak sinusoidal signals, with 2.5 V offset and a phase

shift of 120 degrees. These sensors can be used for a fine positioning of the rotor. Triton Go analog halls inputs main features are shown in next table:

Specification	Value
Type of inputs	Non-isolated Single ended analog filtered ESD protected
Number of inputs	3
ESD capability	IEC 61000-4-2 (ESD) $\pm 30$ kV (air), $\pm 30$ kV (contact)
Maximum recommended working frequency	1 kHz
1st order filter cutting frequency (-3dB)	10 kHz
Sampling frequency	10 ksps
Voltage range	0 ~ 5 V (10 bits)
Maximum voltage range	-0.3 ~ 5.3 V

Next figure illustrates the circuit model for one of the linear Halls inputs. Note that analog halls pins are shared with [Digital Halls interface](#) (see page 65). To avoid any signal distortion, when analog halls interface is selected, the 1 k $\Omega$  pull-up is disconnected automatically.

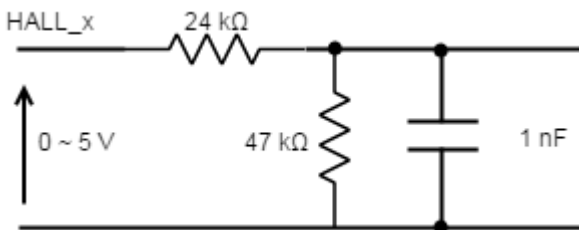

Next figure shows how to connect the linear Halls to the Triton Go Servo Drive. Refer to [Feedback wiring recommendations](#) (see page 78) for more information about connections and wires.

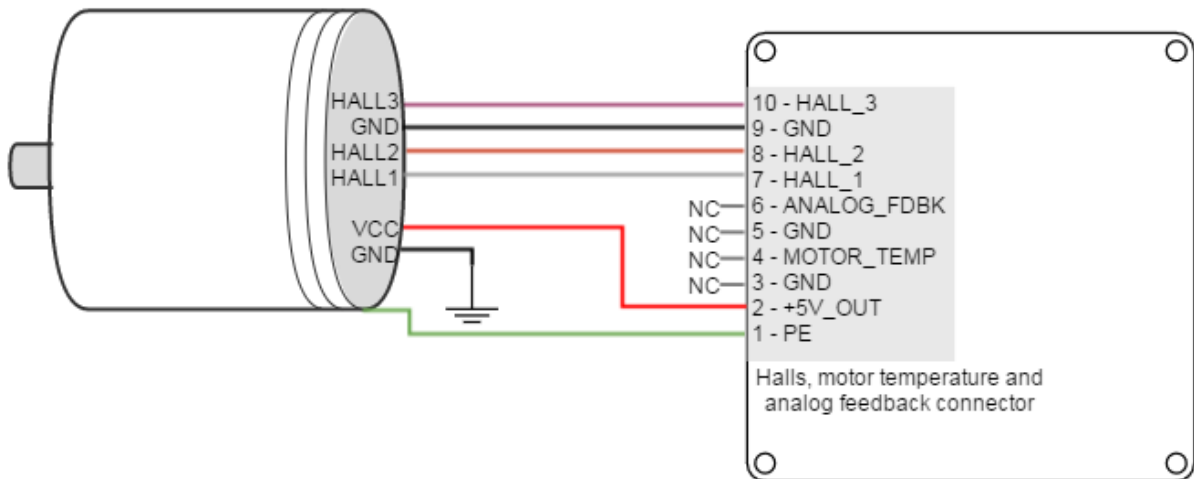

### 7.4.3 Digital Incremental Encoder

Triton Go can use single ended or differential digital incremental encoder inputs (also known as quadrature incremental encoders) for velocity and/or position control, as well as commutation sensor. The encoder provides incremental position feedback that can be extrapolated into precise velocity or position information. Using high resolution encoders allows Triton Go Servo Drive to use sinusoidal commutation.

Channel A and channel B signals should have a phase shift of 90 degrees, indicating the rotation direction. Based on the pulses frequency, the drive can calculate the motor velocity and position.

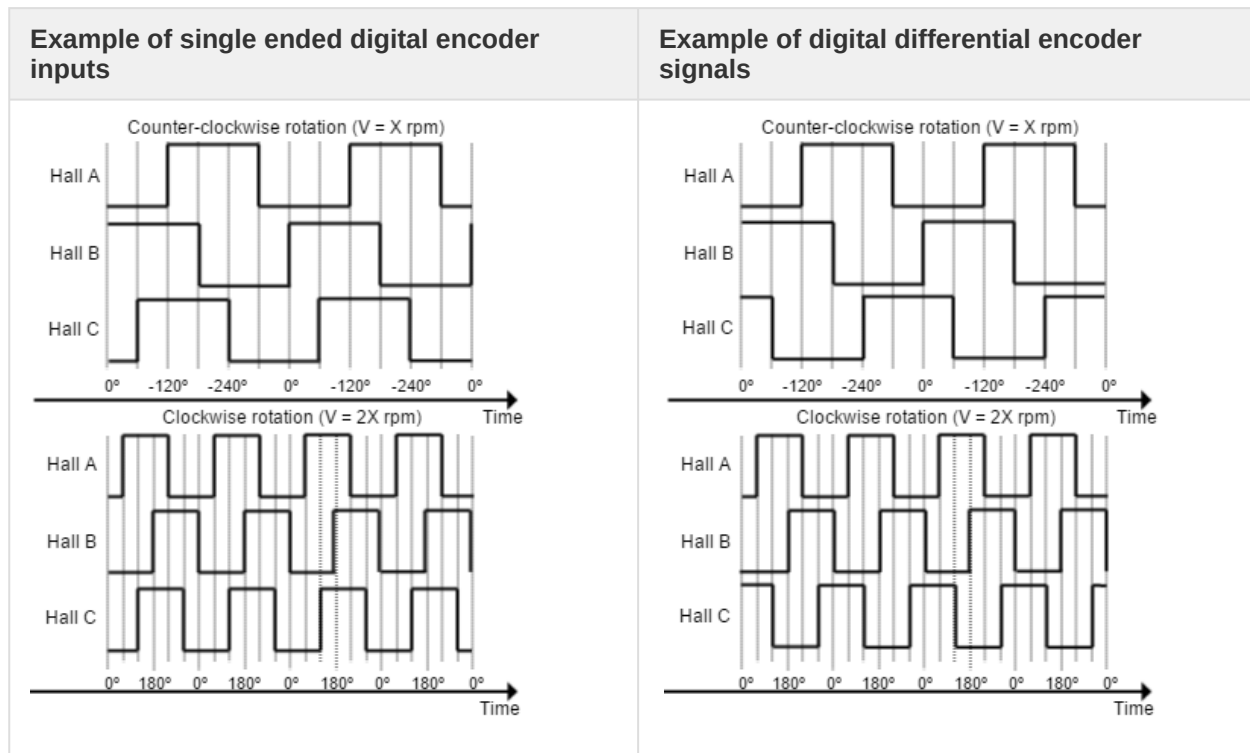

 **High precision applications**

High resolution motor mounted encoders allows excellent velocity and position control at all speeds. Encoder feedback should be used for applications requiring precise and accurate velocity and position control. Digital encoders are especially useful in applications where low-speed smoothness is the objective.

The Triton Go Servo Drive has one differential digital encoder interface, with optional index signal input. Index (Z) is a single pulse per revolution signal that indicates an absolute position. Next table lists digital encoder inputs main features.

Specification	Value
Type of inputs	Non-isolated. Differential or single ended. ESD protected
Number of inputs	3 (A, B and Index)
ESD capability	IEC 61000-4-2 (ESD) ± 30 kV (air), ± 30 kV (contact)
Nominal voltage range	0 ~ 5 V
Maximum voltage range	-0.5 ~ 5.5 V
Maximum recommended working frequency	10 MHz (differential)
1st order filter cutting frequency (-3 dB)	6 MHz
Maximum readable pulse frequency	30 MHz
Termination resistor	220 Ω (between ENC_x+ and ENC_x-)
Bias resistors	ENC_x+ (positive input) 1 kΩ to 5 V ENC_x- (negative input) 1 kΩ to 2.5 V (equivalent)

For encoder signal reception, an analog differential line receiver with an hysteresis comparator is used. The high signals (ENC\_A+, ENC\_B+ and ENC\_Z+) are pulled up to +5 V, and the low signals (ENC\_A-, ENC\_B- and ENC\_Z-) are biased to 2.5 V. This arrangement let the user to connect either differential output encoders or single ended encoders (both open collector and totem pole).

The encoder interface also accepts an RS-422 differential quadrature line driver signal in the range of 0 V to 5 V, up to 10 MHz. When single ended encoder is connected, only high signals (ENC\_A+, ENC\_B+ and ENC\_Z+) must be used.

Next figures illustrate how to connect a differential and a single ended encoder to the Triton Go Servo Drive. Refer to [Feedback wiring recommendations](#) (see page 78) for more information about connections and wires.

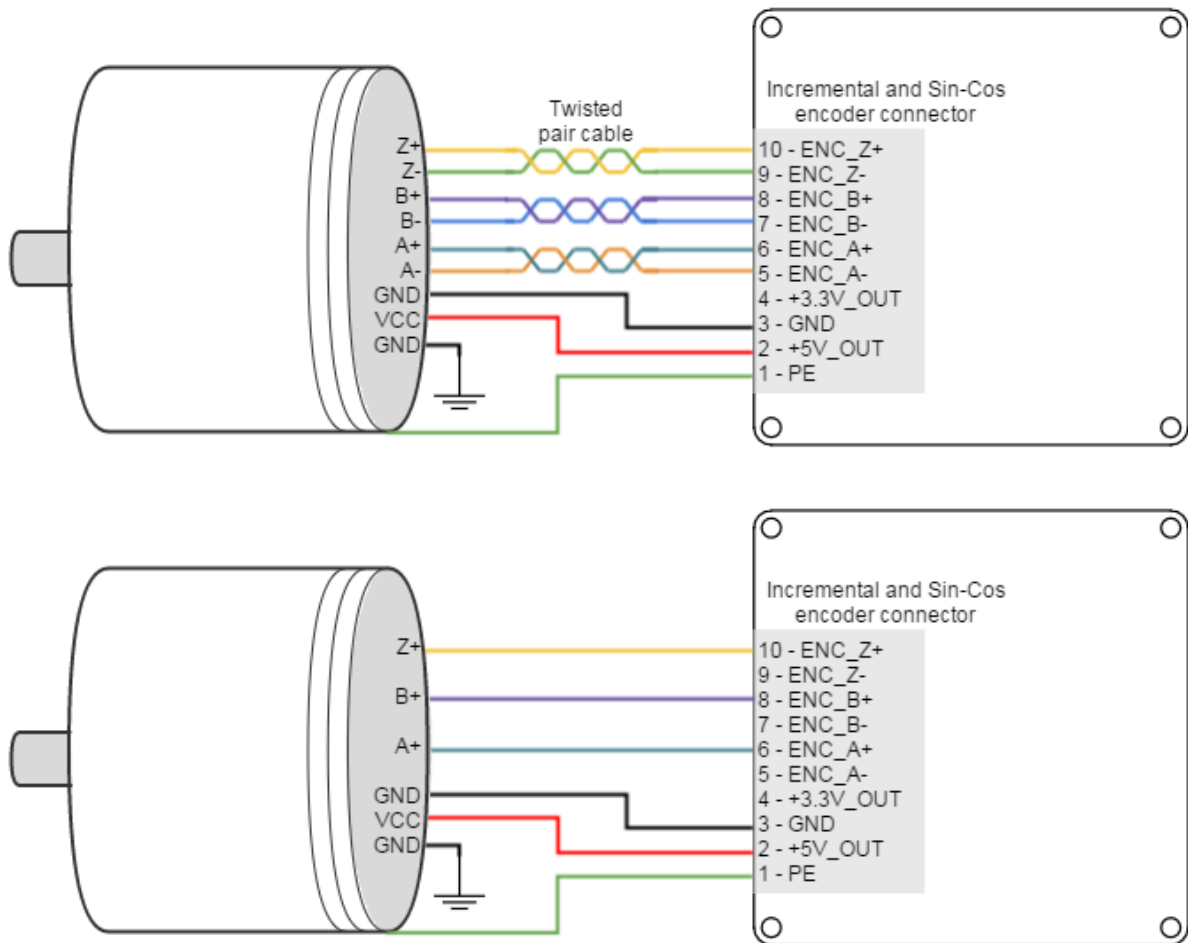

Next figure shows the circuit model of the digital encoder inputs.

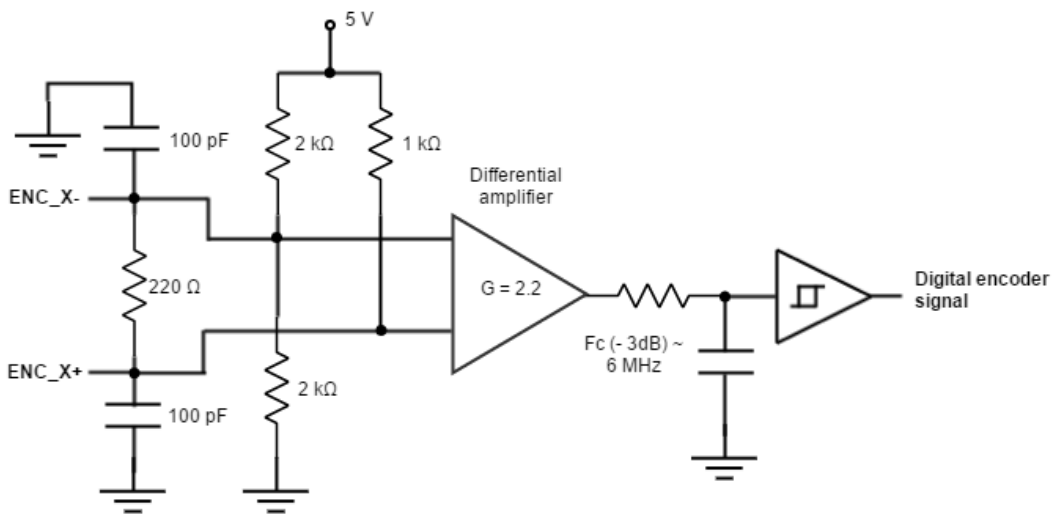

### Digital encoders with single ended 24 V outputs

Triton Go Servo Drive can also interface single ended digital encoders with output voltages higher than 5 V, for instance 24 V PLC level encoder. With the use of series connected limiting resistors, Triton Go is able to read encoder counts correctly while the inputs are correctly protected.

A 4.7 kΩ, 1/4 W resistor should be used in series with the ENC\_X+ input and leave the ENC\_X- (inverting) floating.

#### 7.4.4 Analog encoder (Sin-Cos encoder) interface

The Triton Go Servo Drive can use analog encoder (also known as Sin-Cos encoder) as position and velocity feedback element. This sensor provide a pair of quadrature sine and cosine signals as the motor moves, which frequency depends on the motor speed. The signals may be generated by optical or magnetic means. For noise immunity the signals are typically transmitted differentially from the encoder to the sensor interface electronics.

Pin	Signal description	Signal example
SIN+	Sine wave with 2.5 V offset and 0.5 Vpp	
SIN-	Same as SIN+, but with 180° phase shift	
COS+	Cosine with 2.5 V offset and 0.5 Vpp	
COS-	Same as COS+, but with 180° phase shift	
REF+	One sine half wave per revolution as index pulse	
REF-	Same as REF+, but with 180° phase shift	

#### ✔ Sin-Cos calibration

Analog encoder signals are not always a perfect sine and cosine. For this reason, Triton Go includes sin-cos calibration and adjustment parameters. For further information see the E-Core [Sin-Cos encoder configuration](http://doc.ingeniamc.com/display/EMCL/SinCos+encoder+configuration)<sup>68</sup>.

An automatic calibration based on Lissajous curves is included in [MotionLab](http://ingeniamc.com/software#motionlab)<sup>69</sup>, allowing an easy adjustment.

Next table summarizes analog encoder inputs main features.

<sup>68</sup> <http://doc.ingeniamc.com/display/EMCL/SinCos+encoder>

<sup>69</sup> <http://ingeniamc.com/software#motionlab>



Specification	Value
Type of inputs	Differential analog input (switching to digital automatically at high speed). ESD protected
Number of inputs	3 (SIN, COS, REF)
ESD capability	IEC 61000-4-2 (ESD) $\pm 30$ kV (air), $\pm 30$ kV (contact)
Typical voltage range	2.25 ~ 2.75 V
Maximum voltage range	-0.5 ~ 5.5 V
Maximum recommended working frequency	1 kHz used as analog encoder 10 MHz used as digital encoder
1st order filter cutting frequency (-3 dB)	6 MHz
Sampling rate (analog)	10 ksps
Maximum readable pulse frequency (digital)	30 MHz
Input impedance	220 $\Omega$ resistive differential. 100 pF capacitive. 1 k $\Omega$ to GND
Resolution	10 bits

Next figure shows how to connect a Sin-Cos encoder to Triton Go Servo Drive. Refer to [Feedback wiring recommendations](#) (see page 78) for more information about connections and wires.

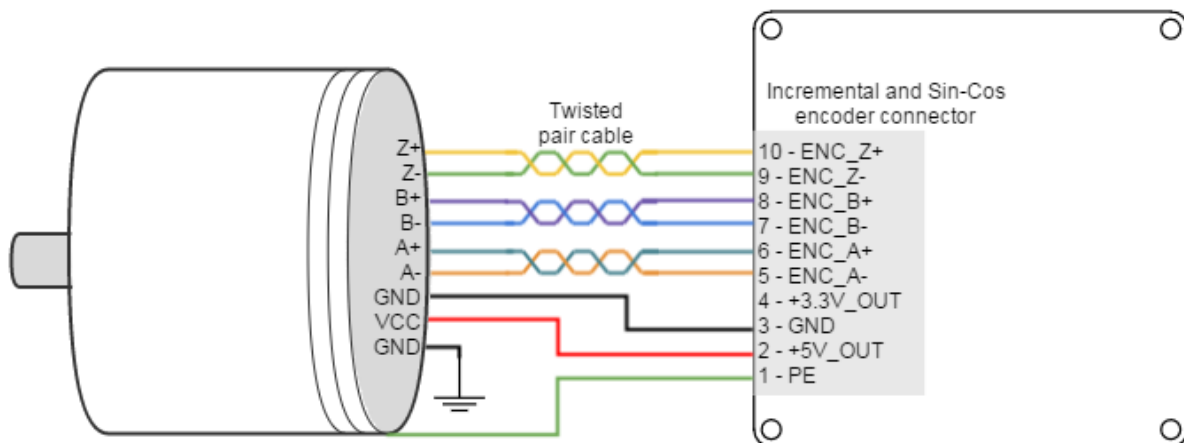

Circuit model for each differential channel (A, B, REF) is shown in the next figure.

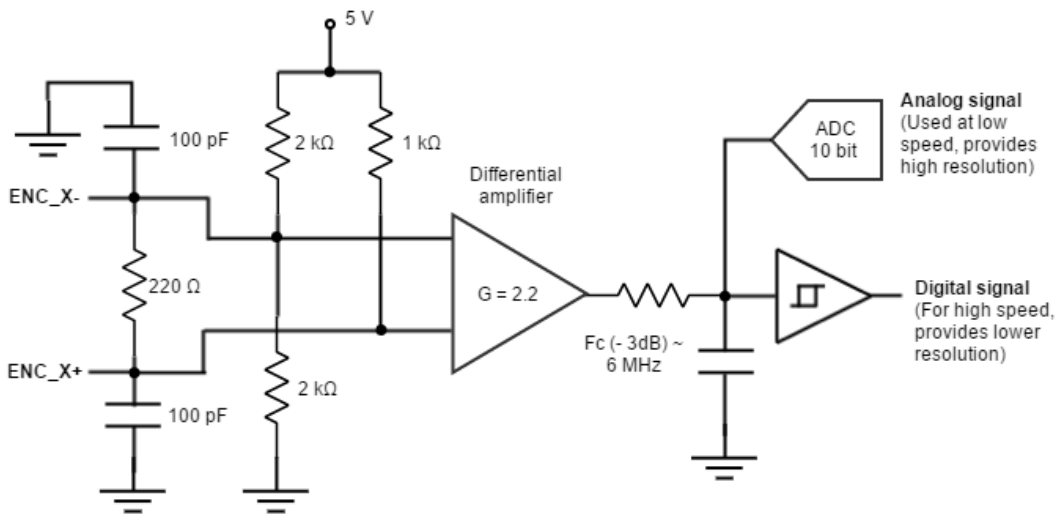

### 7.4.5 Absolute encoder interface

The Triton Go has an Absolute encoder connector that can be used as position and velocity feedback element. This sensor generates digital data that represent the encoder actual position. From the position information, speed and direction of motion is calculated. The position is not lost even if the encoder is powered down, this means it is not necessary to move to a reference position as with incremental type encoders.

Next table shows the absolute encoder inputs electrical specifications.

Specification	Value
Type of inputs	Non-isolated. Differential. ESD protected
ESD capability	IEC 61000-4-2 (ESD) ± 30 kV (air), ± 30 kV (contact)
Number of inputs	2 (CLK and DATA)
Nominal voltage range	0 ~ 5 V
Maximum voltage range	-13 ~ 16.5 V
Maximum readable frequency (SSI)	1 kHz
Termination	120 Ω on data line

Next Figure shows how to connect an Absolute encoder to Triton Go Servo Drive. Refer to [Feedback wiring recommendations](#) (see page 78) for more information about connections and wires.

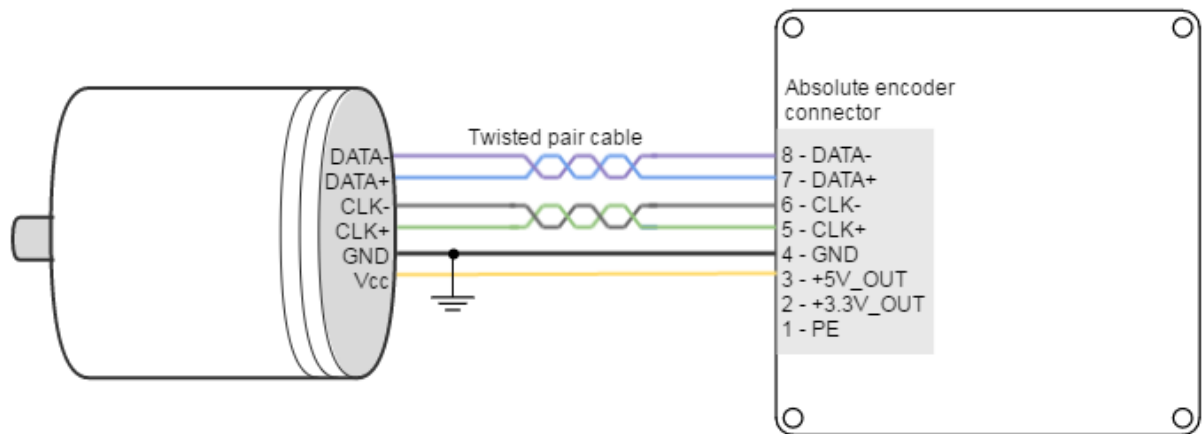

Circuit model for the absolute encoder receiver channels is shown in the next figure.

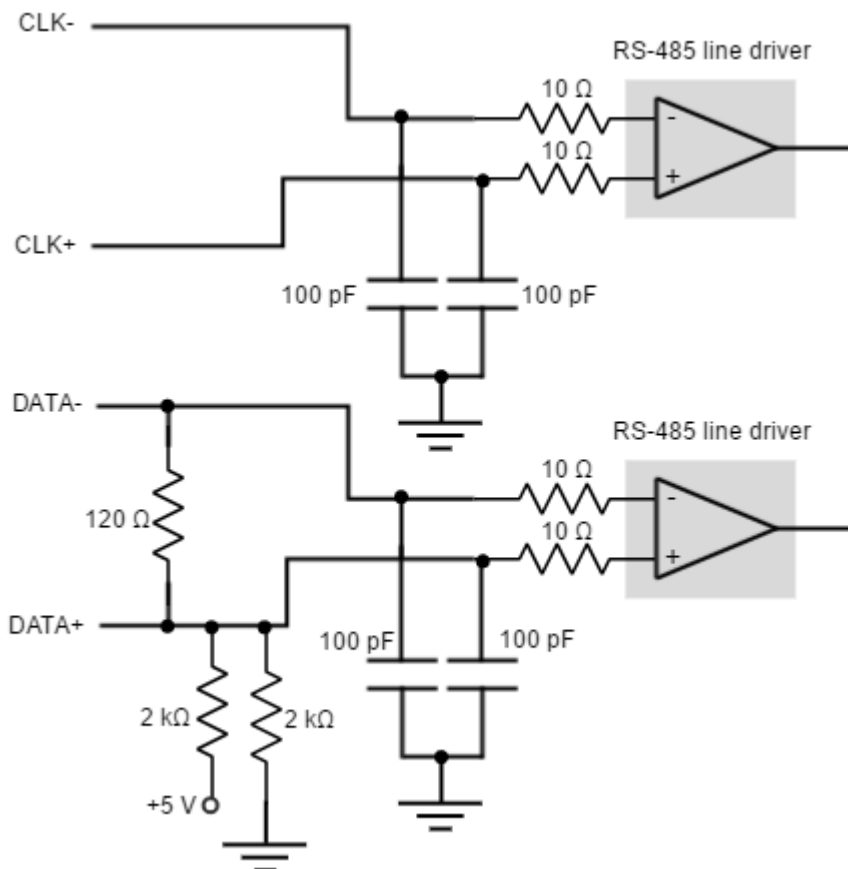

#### 7.4.6 Digital input feedback - PWM encoder

Triton Go Servo Drive can also use a PWM encoder connected through the I/O and LEDs connector as a feedback element. A PWM encoder provides a Pulse Width Modulated (PWM) signal with a duty cycle proportional to the angle (position) of the rotor. This feedback can be interfaced through the high-speed digital input 1 (**HS\_GPI1**).

Both differential and single-ended PWM encoders can be used. Further specifications about the PWM input can be found in [I/O connection section](#) (see page 79).

Next figure illustrates PWM feedback input for different rotor positions:

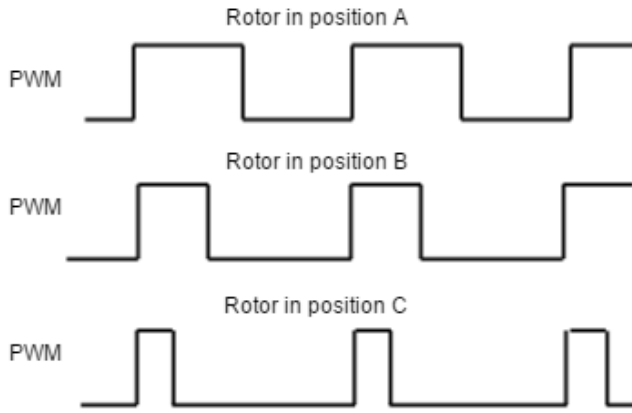

Next figures illustrates how to connect differential and single ended PWM encoders to the Triton Go Servo Drive:

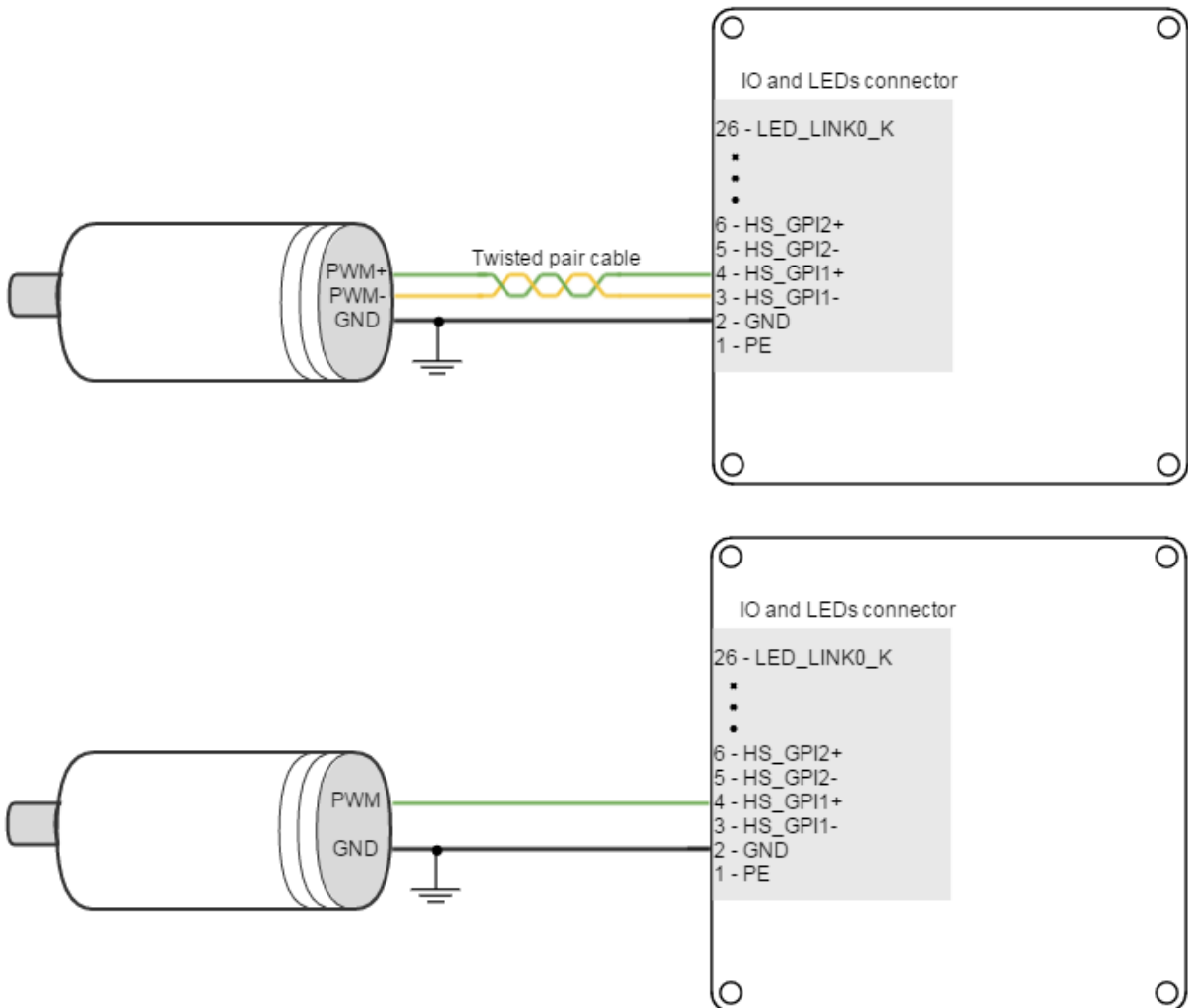

Refer to [Feedback wiring recommendations](#) (see page 78) for more information about connections and wires.

### 7.4.7 Analog input feedback

Triton Go Servo Drive can also use analog feedback systems connected through the I/O connector. From the voltage level of one analog input, the position or velocity of the rotor can be calculated. The Triton Go have 2 analog inputs that can be used for feedback input, each one with a different input range. The input used as feedback can be selected by software. Further specifications about the analog inputs input can be found in [I/O connection section](#) (see page 79).

Refer to [Feedback wiring recommendations](#) (see page 78) for more information about connections and wires.

### Potentiometer

Typically, a potentiometer is used as a position feedback, providing a voltage proportional to the rotor position.

The following picture shows how to connect a potentiometer as a position sensor using analog input 1:

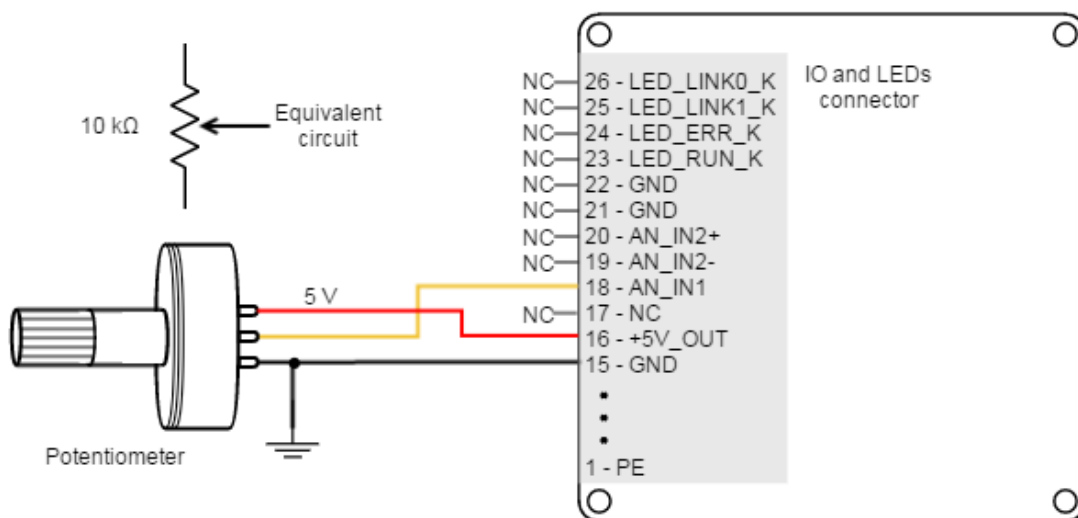

#### ✔ Recommended potentiometer resistance

Potentiometers with high values of resistance (> 10 kΩ) can result in non linear behavior due to its the drive parallel input resistors. High resistance values also reduce the signal to noise ratio, making it easier to have disturbances and reducing the quality of the measure.

However, a very small value of resistance may also consume too much power and cause self heating (which causes additional variations on resistance). Therefore, **use the smallest value of resistance** that:

- Does not exceed 1/2 of the potentiometer power rating (safety margin to prevent self heating).
- Does not exceed the +5V\_OUT current capacity.

Typically 1 kΩ to 10 kΩ will be preferred.

### DC tachometer

The Triton Go Servo Drive can use a DC tachometer for velocity feedback through the I/O connector. A DC tachometer provides an analog signal whose voltage level is proportional to the rotor speed.

Next figure illustrates how to connect a DC tachometer with differential output to the Triton Go Servo Drive.

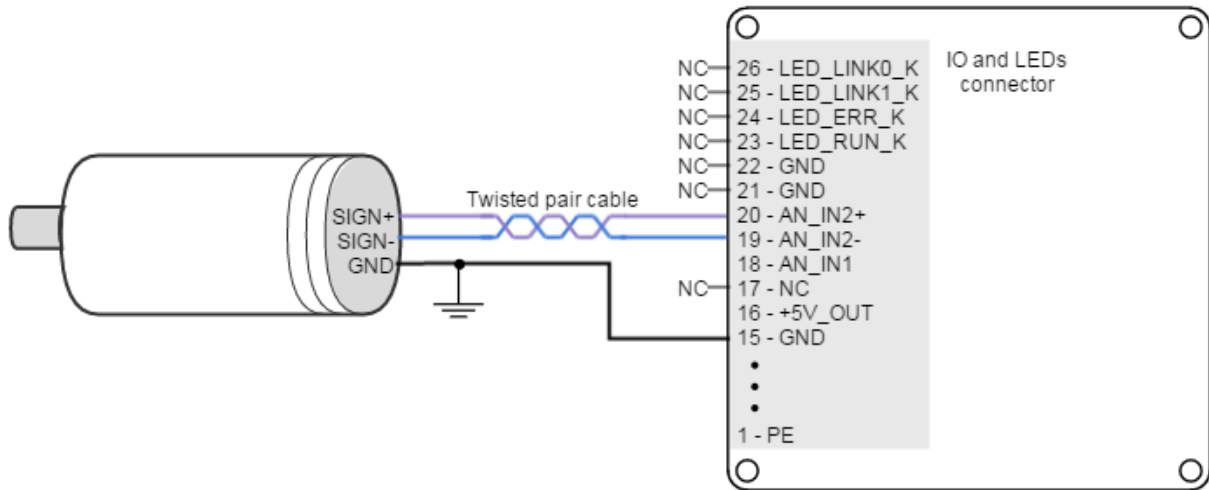

#### 7.4.8 Feedback wiring recommendations

**Signal distortion and electrical noise is a common problem in feedback signals.** These problems can result in a bad position or velocity calculation for both digital feedbacks (gain or loss of counts) and analog feedbacks (wrong voltage levels). To minimize these problems some **wiring recommendations** are shown:

- **Use differential signals** whenever is possible. That is, connect both positive and negative signals of differential feedback sensors. **Use a twisted pair for each differential group of signals** and another twisted pair for the +5 V supply and GND. Twisted-pairs help in elimination of noise because disturbances induced in twisted pairs
- Twisted-pairs help in elimination of noise due to electromagnetic fields by twisting the two signal leads at regular intervals. Any induced disturbance in the wire will have the same magnitude and result in error cancellation.
- **Connect the Triton Go and encoder GND signals** even if the encoder supply is not provided by the drive.
- **Connection between Triton Go PE and the motor metallic housing is essential** to provide a low impedance path and minimize noise coupling to the feedback. For further information, see [Protective Earth wiring](#) (see page 52).
- **For better noise immunity, use shielded cables**, with the shield connected to PE only in the drive side. Never use the shield as a conductor carrying a signal, for example as a ground line.
- It is essential to **keep feedback wiring as far as possible from motor**, AC power and all other power wiring.

#### Recommendations for applications with close feedback and motor lines

In some applications, like in the subsea market, where additional connectors and cables are a problem, the feedback cannot be wired separately from the motor and power lines. This creates noise problems that could

result in hall sensors wrong commutation errors or encoder loss of counts. For these applications we recommend:

- Use a common mode choke on the motor phases. This single action can reduce common mode noise drastically and will solve most problems. See recommended wiring in [Motor and shunt braking resistor wiring](#) (see page 59).
- Ensure the motor housing is well connected to protective earth and the system chassis (PE).
- If possible, minimize power supply voltage. This will also minimize the electromagnetic noise generated by the motor switching.
- Add additional RC low pass filters on the feedback inputs. The filter should attenuate at a frequency above the maximum speed signal to prevent loss of counts and signal distortion. Preferably use resistors with low values to prevent distortion to the servo drive input circuit at low frequency (< 500 Ω). Use ceramic capacitors with good quality dielectric, like C0G.

For further information contact [Ingenia engineers for support](#)<sup>70</sup>.

## 7.5 I/O connections

The Triton Go Servo Drive provides various inputs and output terminals for parameter observation and drive control options. These inputs can also be used for some feedback purposes (see [Feedback connections](#) (see page 64)).

The input and output pins are summarized below:

- 4 x 5 V general purpose non-isolated single ended digital inputs (see page 79) (GPI1, GPI2, GPI3, GPI4).
- 2 x 5 V high-speed non-isolated differential digital inputs (see page 82) (HS\_GPI1, HS\_GPI2).
- 1 x 0 ~ 5 V single ended 12 bits analog input (see page 87) (AN\_IN1).
- 1 x ±10 V differential 12 bits analog input (see page 87) (AN\_IN2).
- 4 x 5 V non-isolated digital outputs (see page 90) (GPO1, GPO2, GPO3, GPO4).

Apart from the general purpose inputs, Triton Go has a dedicated analog input for measuring the **motor temperature** (see page 95).



### Motor brake input

Digital outputs (GPO1, GPO2, GPO3 and GPO4) can also be used as a **motor brake output** (see page 94).



### Wiring recommendations

Wiring recommendations for I/O signals are the same than for feedback signals. Detailed information about good wiring practices can be found in [Feedback wiring recommendations](#) (see page 78).

### 7.5.1 General purpose single ended digital inputs interface (GPI1, GPI2, GPI3, GPI4)

The general purpose non-isolated digital inputs are ready for 5 V levels, but are 24 V tolerant. Next table show their electrical specifications.

<sup>70</sup> <http://ingeniamc.com/support>

Specification	Value
Number of inputs	4 (GPI1, GPI2, GPI3, GPI4)
Type of input	Single ended. Low-pass filtered. ESD protected
ESD capability	IEC 61000-4-2 (ESD) $\pm 30$ kV (air), $\pm 30$ kV (contact)
Input current	0.17 mA @ 5 V; 1 mA @ 15 V
High level input voltage	$4\text{ V} < V_{in} < 24\text{ V}$
Low level input voltage	$0 < V_{in} < 1\text{ V}$
Input impedance	30 k $\Omega$
1st order filter cutting frequency (-3 dB)	20 kHz
Sampling rate	1 ksps
Max delay	2 $\mu$ s

General purpose inputs electrical equivalent circuit is the following:

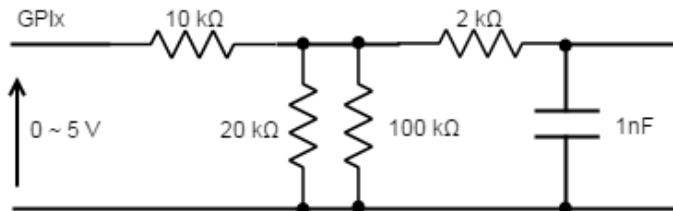

Next figure shows an example of how to connect a switch to the GPI1 and GPI2, using +5V\_OUT (pin 16) pin as a supply source. Same connection could be used for GPI3 and GPI4.



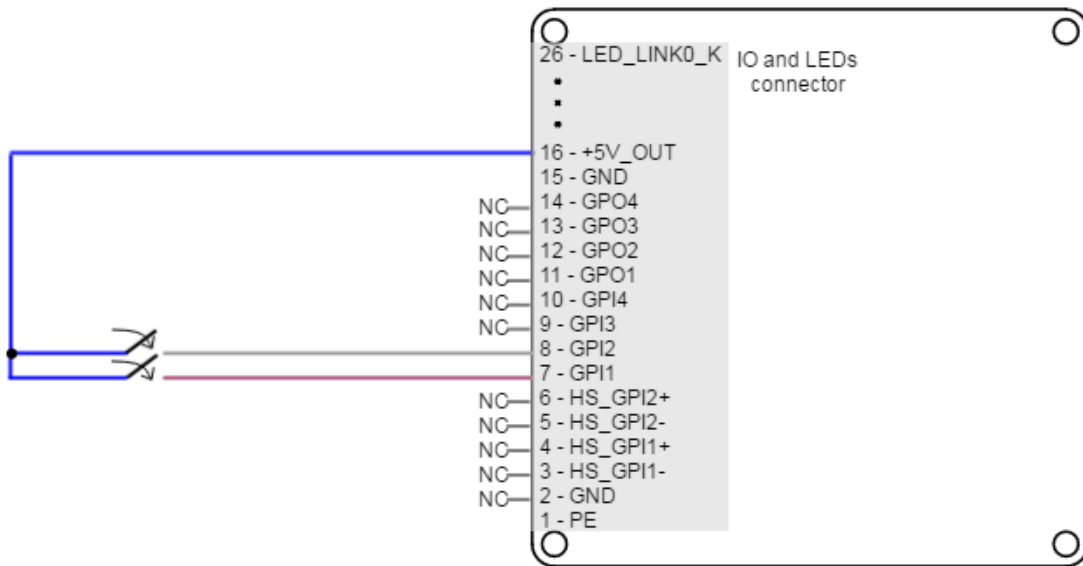

**! Non-isolated I/O**

Triton Go Inputs and outputs are not isolated. The ground of the Triton Go Servo Drive and the ground of the devices connected to I/Os must be the same. Otherwise inputs or outputs may be damaged.

Triton Go Servo Drive general purpose inputs can be used for connecting three-wire sensors. Next figures illustrate the connection of PNP and NPN three-wire sensors in input GPI1 (same wiring can be used for GPI2, GPI3 and GPI4). Pin 16 (+5V\_OUT) can be used as a supply source.

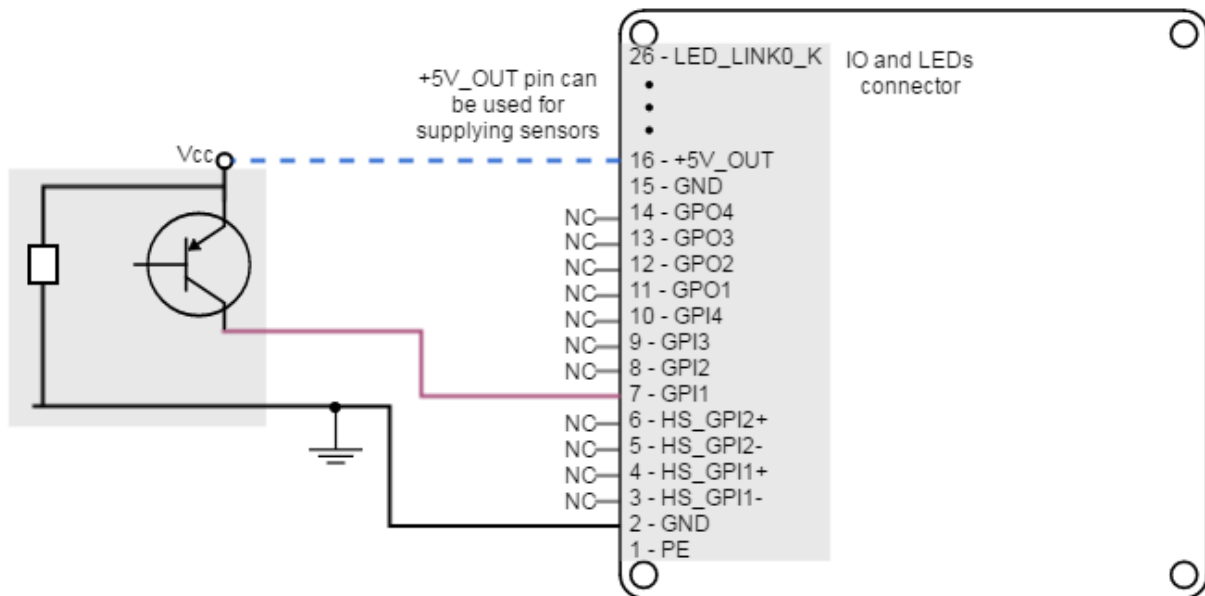

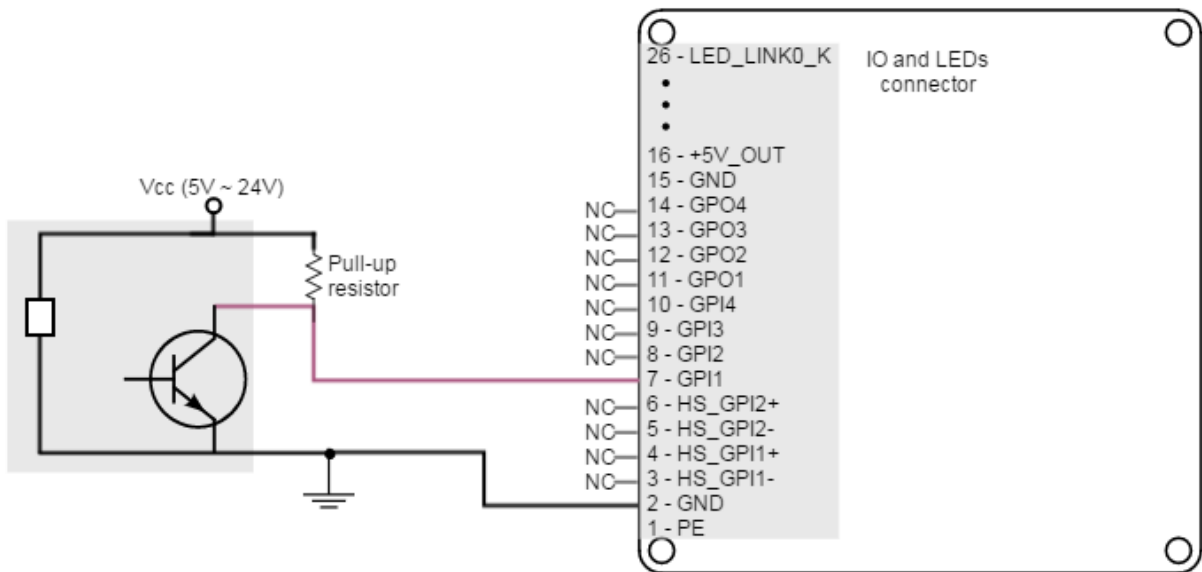

**✓ GPI Pull-up resistors**

Pull-up resistors ensure the desired logic state when the sensor (transistor or relay) is in off-state.

NPN pull-up resistor value must be chosen in order to ensure  $\geq 4\text{ V}$  at the GPI pin considering the  $30\text{ k}\Omega$  input resistance. For a sensor supply of  $5\text{ V}$ ,  $1\text{ k}\Omega$  is recommended. For a sensor supply of  $24\text{ V}$ ,  $10\text{ k}\Omega$  is recommended.

**7.5.2 High-speed digital inputs interface (HS\_GPI1, HS\_GPI2)**

The high-speed (HS) non-isolated digital inputs are ready for  $5\text{ V}$  levels but are  $24\text{ V}$  tolerant. Next table show their electrical specifications.

**⚠ Defect logic value**

Triton Go high-speed inputs are default low-level (OFF). When no signal or load is connected, the board will detect a logic low.

Specification	Value
Number of inputs	2 (HS_GPI1, HS_GPI2)
Type of input	ESD protected Differential and single ended
ESD capability	IEC 1000-4-2 (ESD) $\pm 12\text{ kV}$ (air), $\pm 6\text{ kV}$ (contact)

Input current	0.17 mA @ 5 V; 0.5 mA @ 15 V
High level input voltage	(HS_GPI+ - HS_GPI-) > 150 mV
Low level input voltage	(HS_GPI+ - HS_GPI-) < -600 mV
Maximum working input voltage	±24 V
Maximum recommended frequency	10 MHz
Sampling rate	20 Msps
Total rising delay	65 ns
Total falling delay	55 ns
Maximum common mode voltage ( $V_{CM}$ )	$-7\text{ V} \leq V_{CM} \leq 12\text{ V}$

Next figure shows the circuit model for high-speed digital input. Input is composed of a 3-resistor differential divider, with 10 kΩ resistors, resulting in a total input impedance of 30 kΩ. This **bias resistors allow both single ended and differential input operation**. Noise immunity can be improved by reducing input impedance with a termination resistor between HS\_GPI+ and HS\_GPI-.

High-speed digital inputs electrical equivalent circuit is the following:

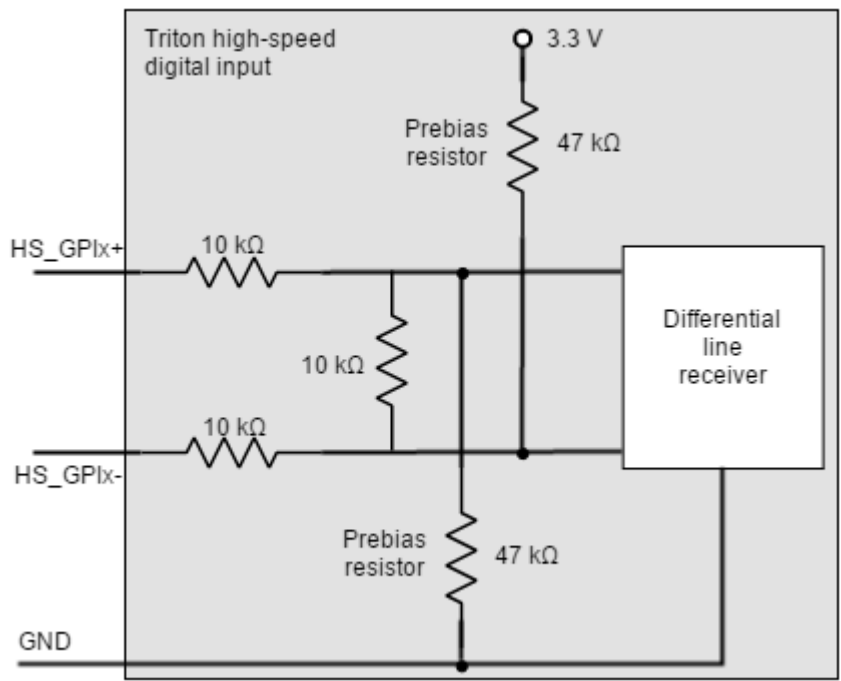

**✔ Single ended operation of HS\_GPI**

In order to use the high-speed digital input in single ended mode, connect HS\_GPIx- to GND and HS\_GPI+ to the desired input signal.

**! Non-isolated I/O**

Triton Go Inputs and outputs are not isolated. The ground of the Triton Go Servo Drive and the ground of the devices connected to I/Os must be the same. Otherwise inputs or outputs may be damaged.

Next figures illustrate how to connect high-speed differential and single ended signals to HS\_GPI1 (same wiring can be used for HS\_GPI2).

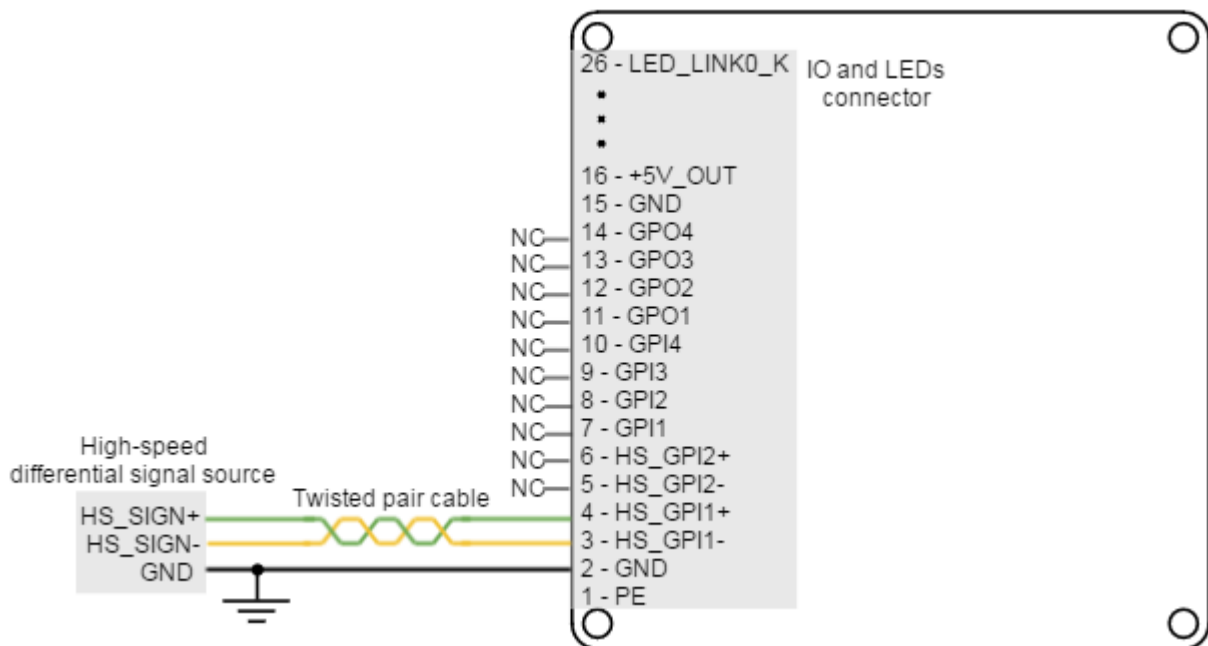

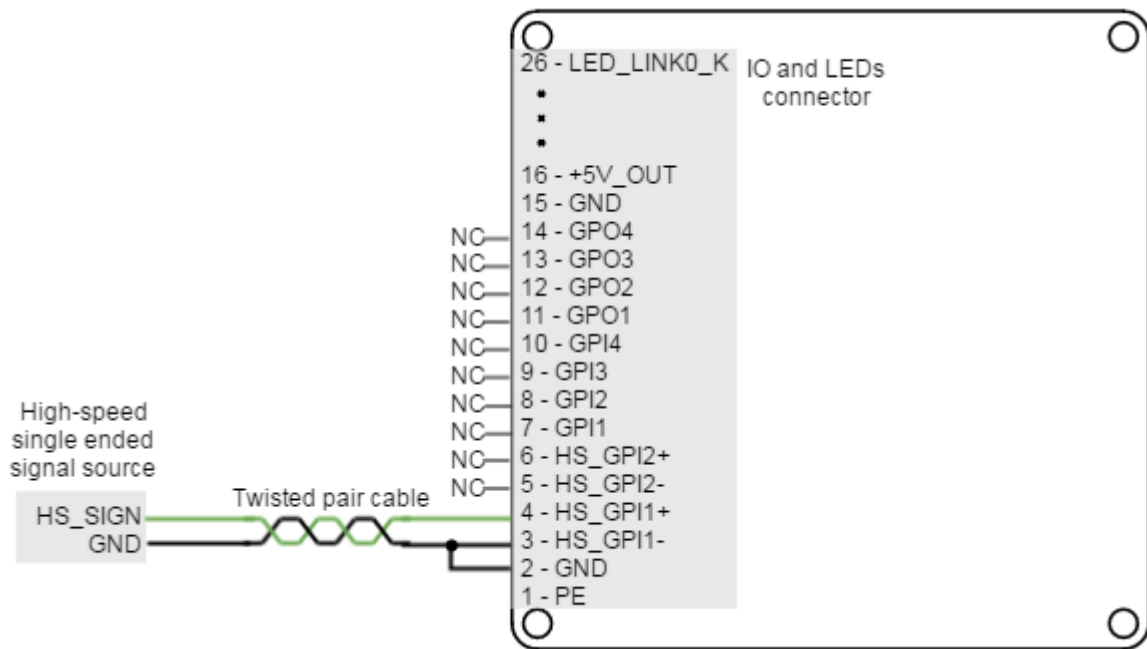

Triton Go Servo Drive high-speed digital inputs can be used for connecting three-wire sensors. Next figures illustrate the connection of PNP and NPN three-wire sensors in input HS\_GPI1 (Same wiring can be used for HS\_GPI2). Pin 16 (+5V\_OUT) can be used as a supply source.

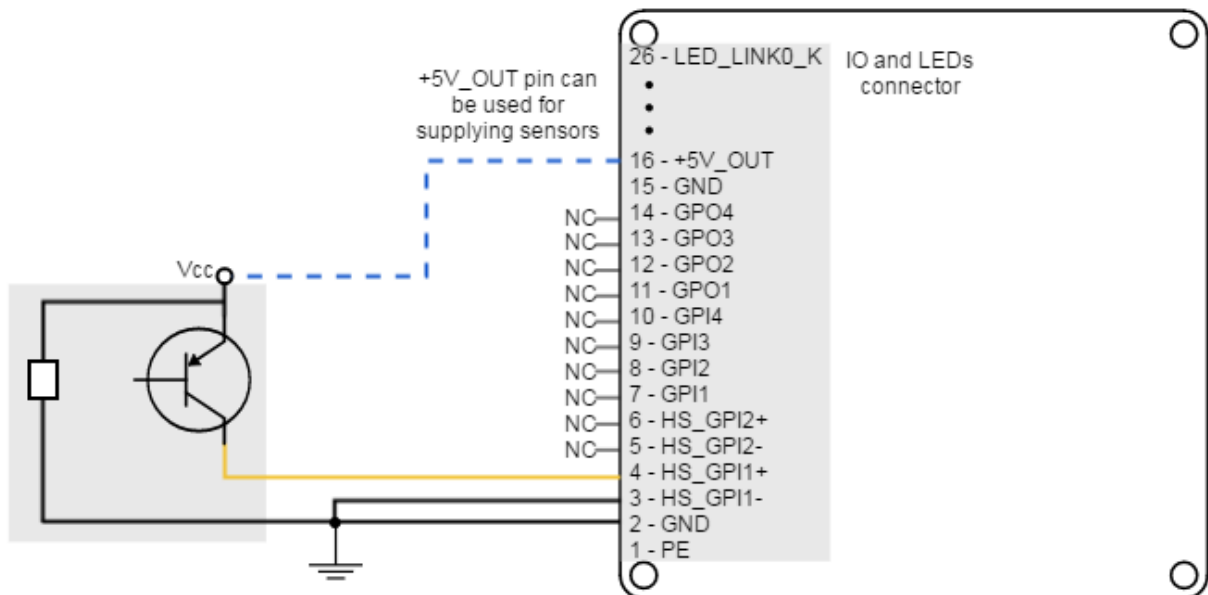

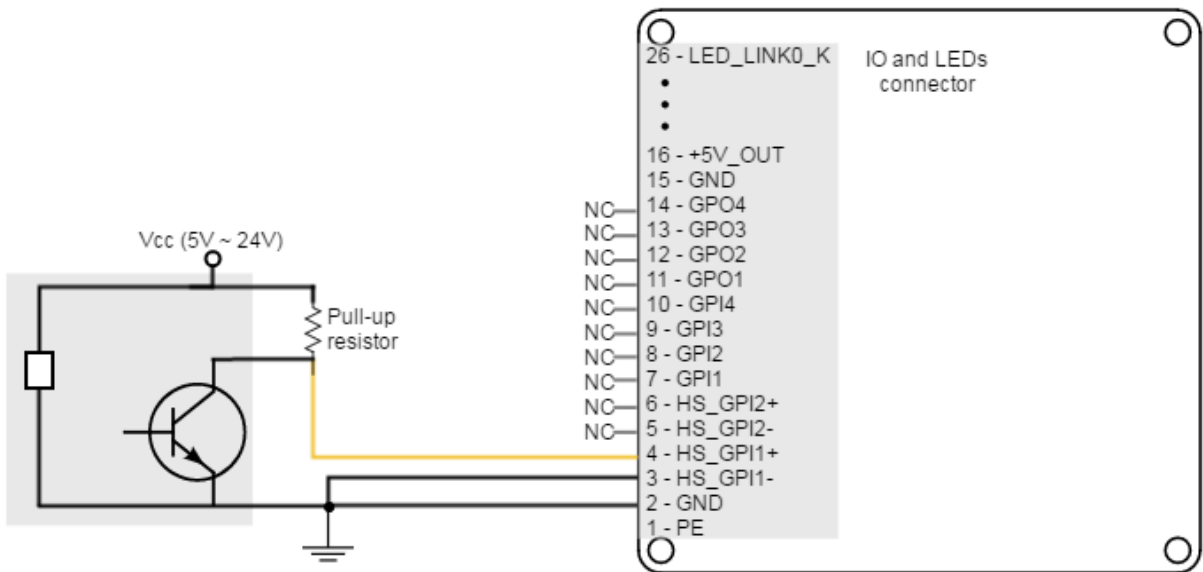

✔ **HS\_GPI pull-up resistors**

Pull-up resistors ensure the desired logic state when the sensor (transistor or relay) is in off-state.

NPN pull-up resistor value must be chosen in order to ensure a positive value in the differential receiver while consuming low current. For a sensor supply of 5 V, 1 kΩ is recommended. For a sensor supply of 24 V, 47 kΩ is recommended.

The connection of a NPN three-wire sensor with a noise filter is shown in the next figure.

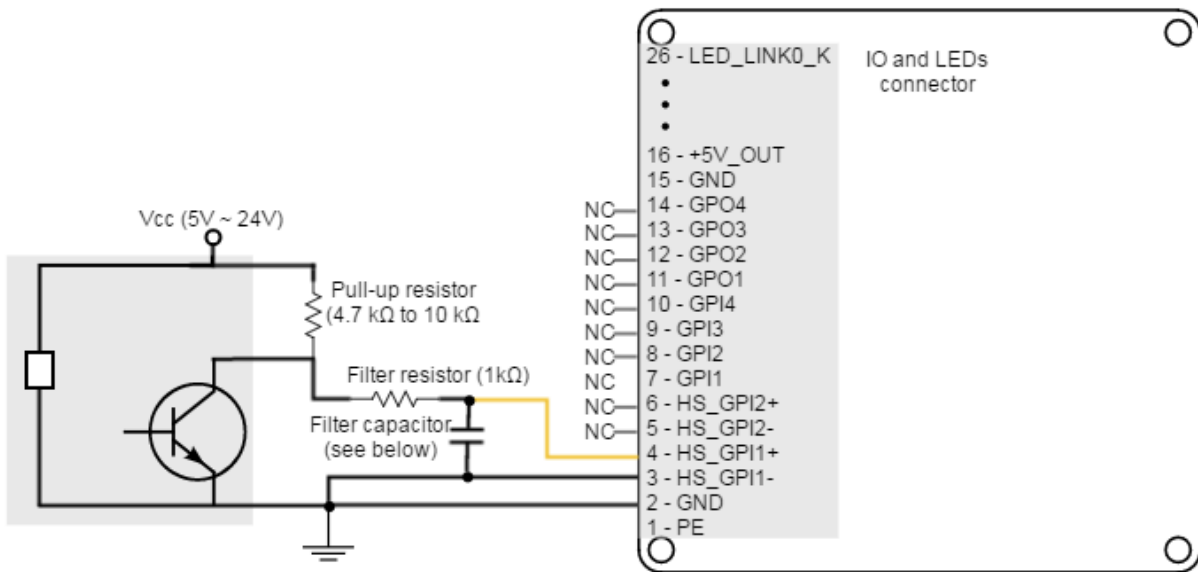

**Calculation of the filter capacitor**

$C_{filter} \approx 1000 / (12 * Freq * (R_{filter} + R_{pull-up}))$   
 Cfilter is in nF. Freq is the maximum signal frequency in kHz. Rfilter and Rpull-up are in kΩ.  
 Choose the biggest standard capacitance close to Cfilter.  
 Use ceramic or film (MKP, MKT) capacitors, place them as close as possible to the driver.

**7.5.3 Analog inputs interface (AN\_IN1, AN\_IN2)**

Triton Go Servo Drive has two 12-bit analog inputs, a single ended one (AN\_IN1) and a differential one (AN\_IN2). Each one of them has a different input voltage range. Next table summarizes the main features of the analog inputs:

Specification	Analog input 1	Analog input 2
Type of inputs	Single ended ESD protected	Differential ESD protected
ESD capability	± 4 kV (contact)	
Analog input resolution	12 bits	
Maximum operating voltage	0 ~ 5 V	±10 V
Maximum common mode voltage (Analog input 2)	-	±10 V
Maximum voltage on any pin (referred to GND)	7 V	24 V
1st order filter cutting frequency (-3dB)	10 kHz	4.4 kHz
Sampling rate (max)	10 ksps	

Next figure shows the circuit model for the analog input 1:

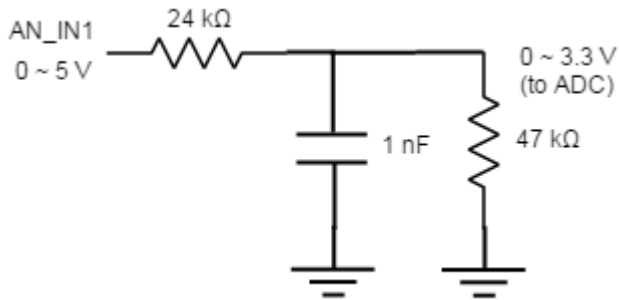

Next figure shows the circuit model for the analog input 2:

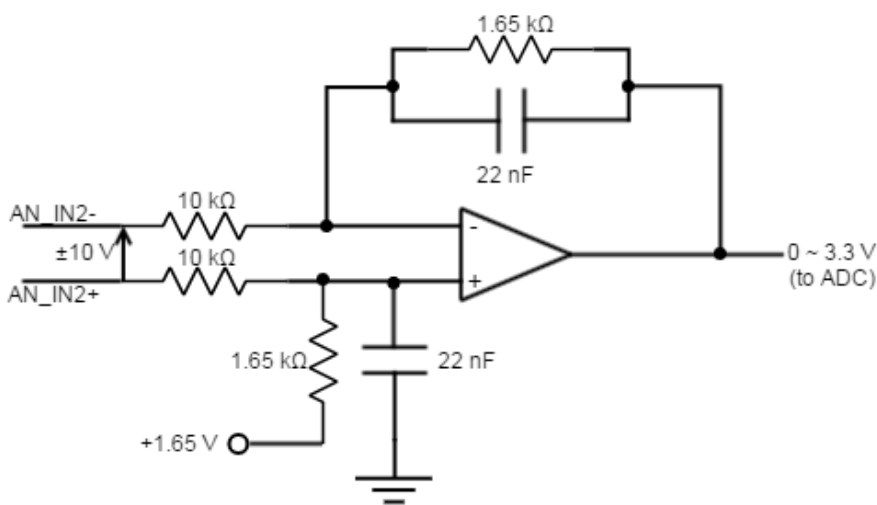

**✔ Extending AN\_IN1 voltage range**

To get a 0 ~ 10 V input range in AN\_IN1 input, place a 71.5 kΩ resistor in series with the input.

**⚠ Non-isolated I/O**

Triton Go Inputs and outputs are not isolated. The ground of the Triton Go Servo Drive and the ground of the devices connected to I/Os must be the same. Otherwise inputs or outputs may be damaged.

Next figure illustrates how to connect an analog single ended source to the Triton Go Servo Drive analog input 1.



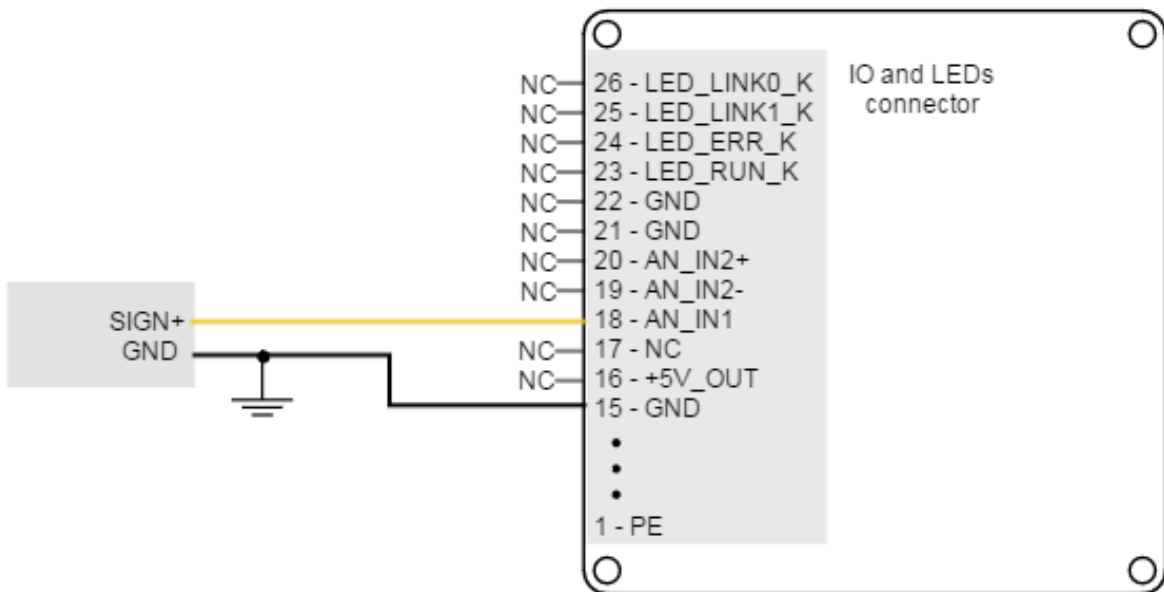

Next figure shows how to interface differential and single ended voltage sources to the differential analog input 2. The differential analog input is typically used as a command source or feedback signal.

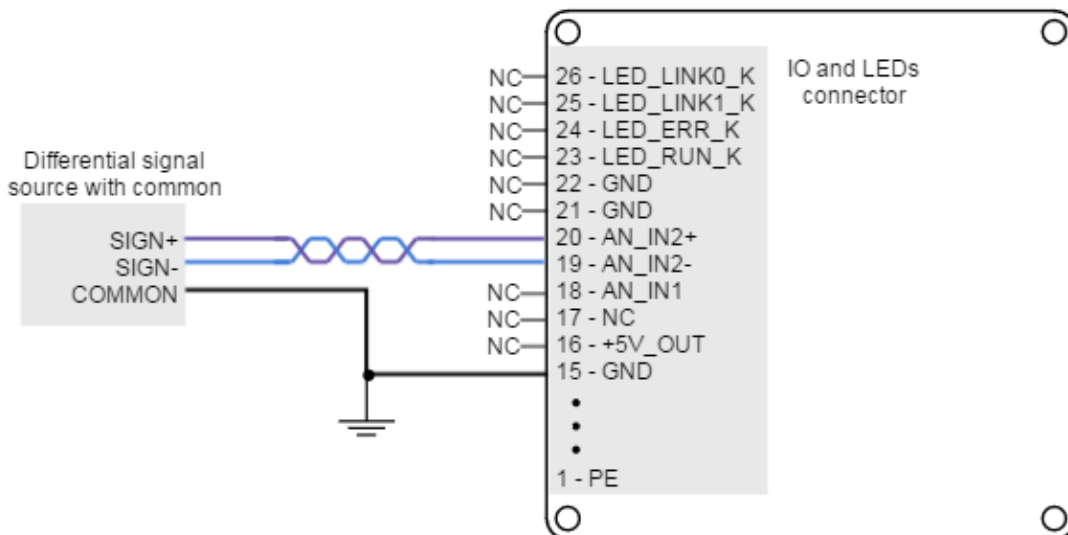

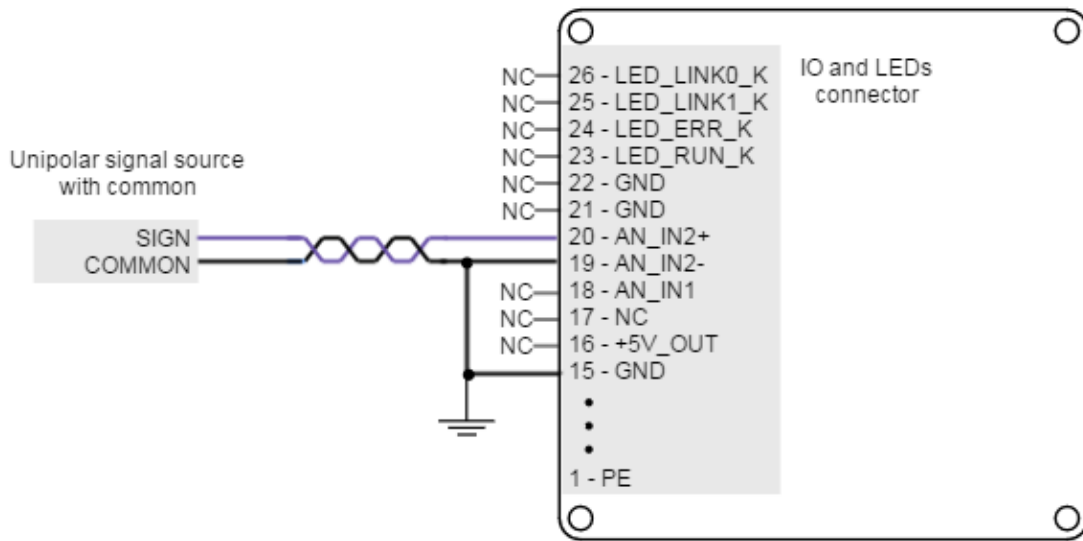

#### 7.5.4 Digital outputs interface (GPO1, GPO2, GPO3, GPO4)

Triton Go Servo Drive has four digital non-isolated outputs. Digital outputs are based on an open drain MOSFET with a weak pull-up to 5 V, and are 24 V tolerant and short-circuit protected. Next table shows their main features:

Specification	Value
Number of outputs	4
Type of output	Open drain output with weak pull-up to 5 V. ESD protected. Overload, short circuit and over-temperature protected with auto restart (self protected MOSFET).
Maximum supply output	30 V (5-24 V typical)
Maximum sink/source current	Source: low current @ 5 V: 5 mA Sink: 1 A @ 5 or 24 V
ON-OFF delay	124 $\mu$ s @ 30 V and $R_{load} = 100\text{ k}\Omega$ 20 $\mu$ s @ 5 V and $R_{load} = 100\text{ k}\Omega$
OFF_ON delay	15 $\mu$ s @ 30 V and $R_{load} = 100\text{ k}\Omega$ 50 $\mu$ s @ 5 V and $R_{load} = 100\text{ k}\Omega$

Max working frequency	1 kHz
-----------------------	-------

Next figure shows digital output circuit model.

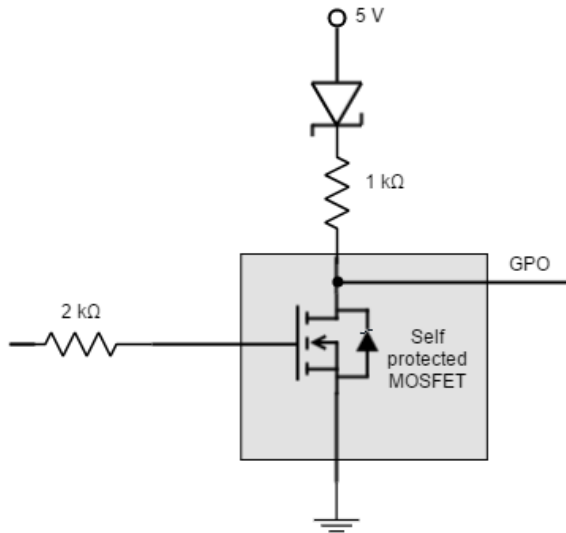

**! Non-isolated I/O**

Triton Go Inputs and outputs are not isolated. The ground of the Triton Go Servo Drive and the ground of the devices connected to I/Os must be the same. Otherwise inputs or outputs may be damaged.

**Wiring of 5V loads**

Loads that require 5V as high-level voltage can be connected directly to the digital output. A wiring example for GPO1 is shown in the next figure (same wiring could be used for GPO2, GPO3 or GPO4).

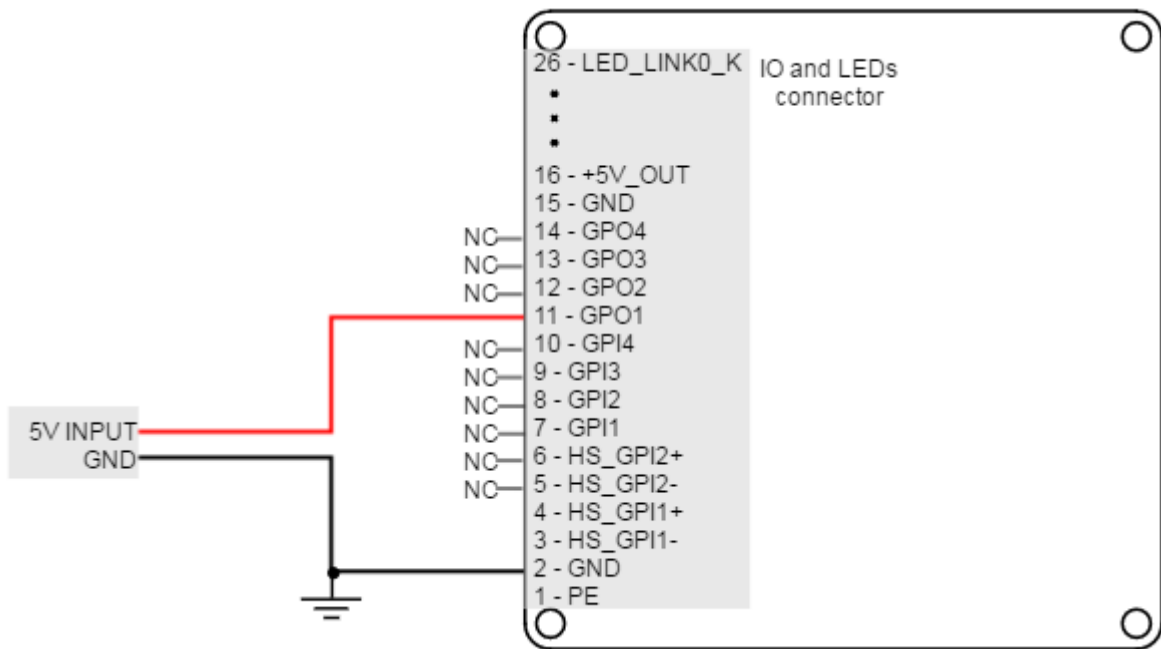

**Wiring of 24V loads**

Loads that require 24V as high-level voltage can also be interfaced with GPO. For this option, an external power supply is needed. The load can be connected with a pull-up to 24V or directly switched with the GPO. Next figures show two example connections to GPO1 (same wiring could be used for GPO2, GPO3 or GPO4).

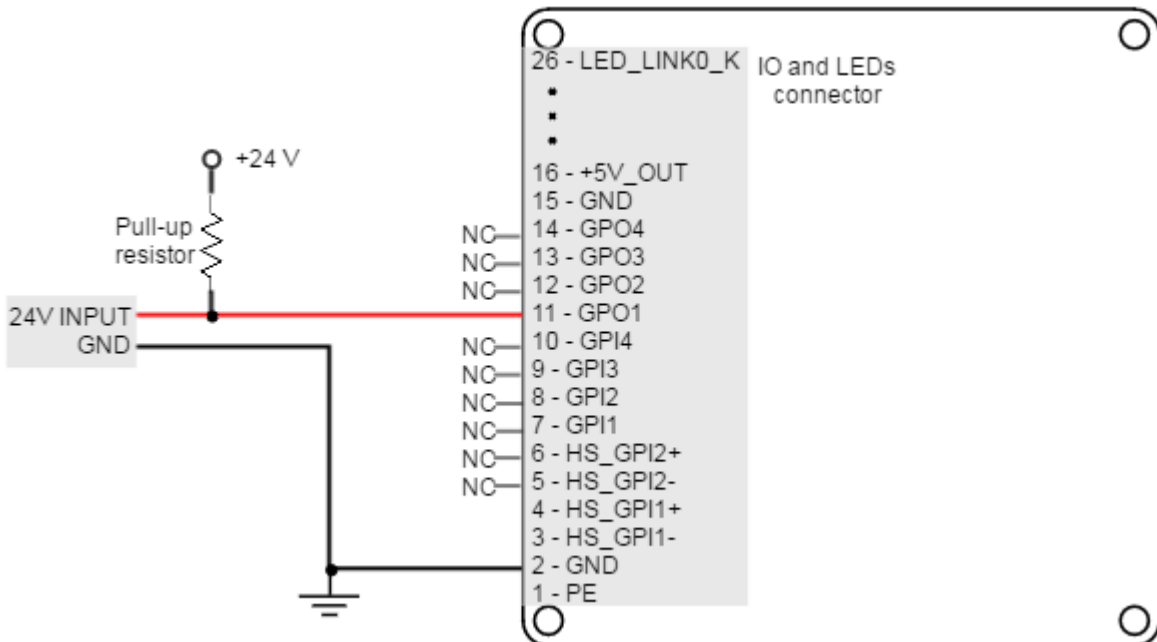

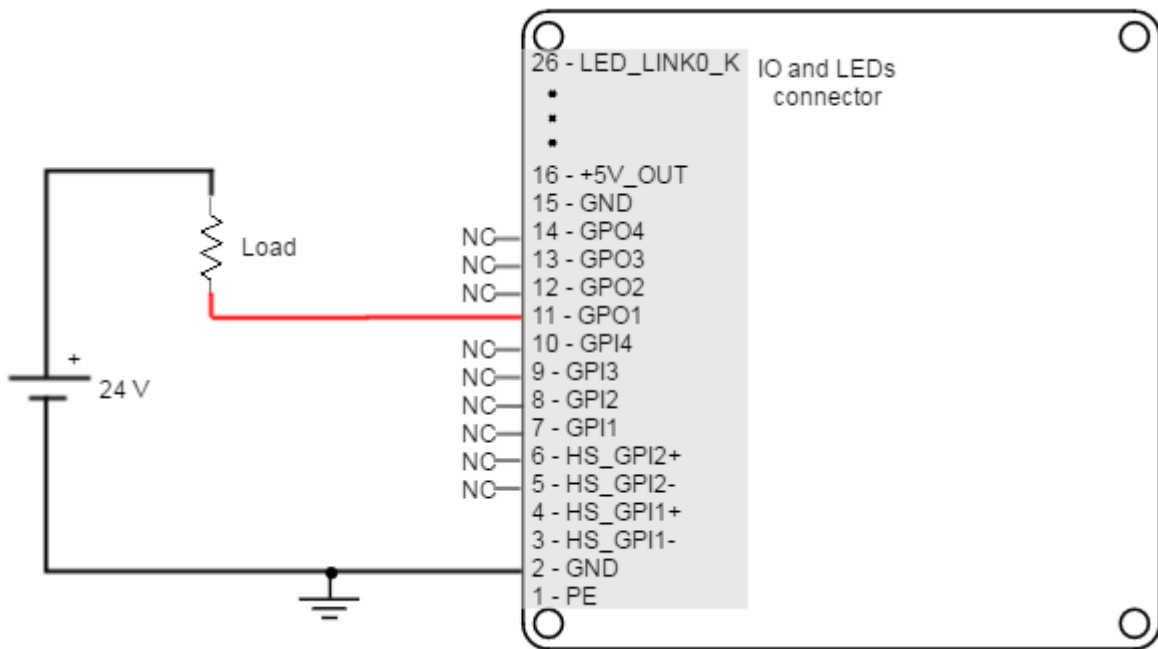

**✔ Interfacing inductive loads**

The switching of inductive loads (like relays or motor brakes) can cause inductive kicking, that is a sudden voltage rise when the current through the inductor is falls to zero. In order to avoid this voltage rise, **it is recommended to place a diode in anti-parallel with the load** (known as freewheeling diode).

Standard rectifier diodes such as [1N4002](http://www.onsemi.com/pub_link/Collateral/1N4001-D.PDF)<sup>71</sup> or [1N4934](http://www.vishay.com/docs/88508/1n4933.pdf)<sup>72</sup> are appropriate for the application.

An alternative to the freewheeling diode is to place a varistor or an RC snubber in parallel with the load.

An example of how to connect an inductive load to GPO1 is shown in the next figure (same wiring could be used for GPO2, GPO3 or GPO4).

<sup>71</sup> [http://www.onsemi.com/pub\\_link/Collateral/1N4001-D.PDF](http://www.onsemi.com/pub_link/Collateral/1N4001-D.PDF)

<sup>72</sup> <http://www.vishay.com/docs/88508/1n4933.pdf>

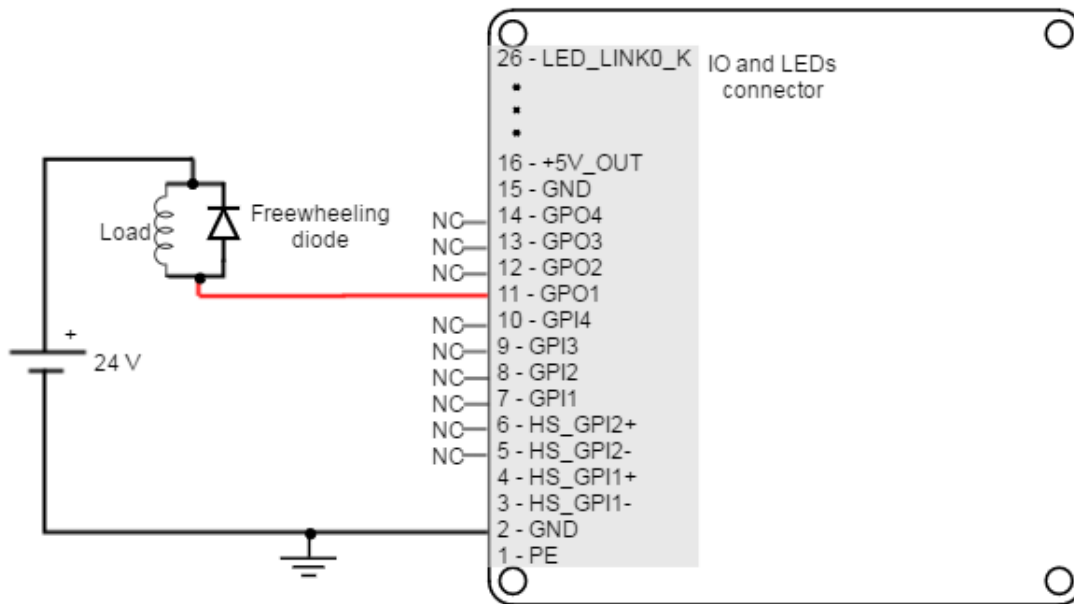

### 7.5.5 Motor brake output (GPO1, GPO2, GPO3, GPO4)

Electromechanical brakes are needed in critical applications where the disconnection of the motor or a lack of electric braking could be dangerous or harmful (i.e. falling suspended loads). Triton Go Servo Drive can use the digital outputs (GPO1, GPO2, GPO3 and GPO4) as a brake output. This output consists on an open drain MOSFET (1 A and 24 V). Further specifications can be found in [Digital outputs interface](#) (see page 90).

#### **i** Motor brake operation

For brake operation of a GPO, this function has to be configured through [Motion Lab](#)<sup>73</sup>.

The brake operation is usually configured for normally locked electromechanical brakes; that is, brakes that by default block the movement of the motor shaft. For this reason, **the switch is controlled with inverted logic, being activated to allow the rotation of the shaft**. This kind of brakes increase the safety of the application, because in a drive power failure, the switch would be opened and therefore the brake activated.

Next figure show how the typical connection using the main supply as brake power supply.

<sup>73</sup> <http://doc.ingeniamc.com/display/i02201/Inputs+Outputs>

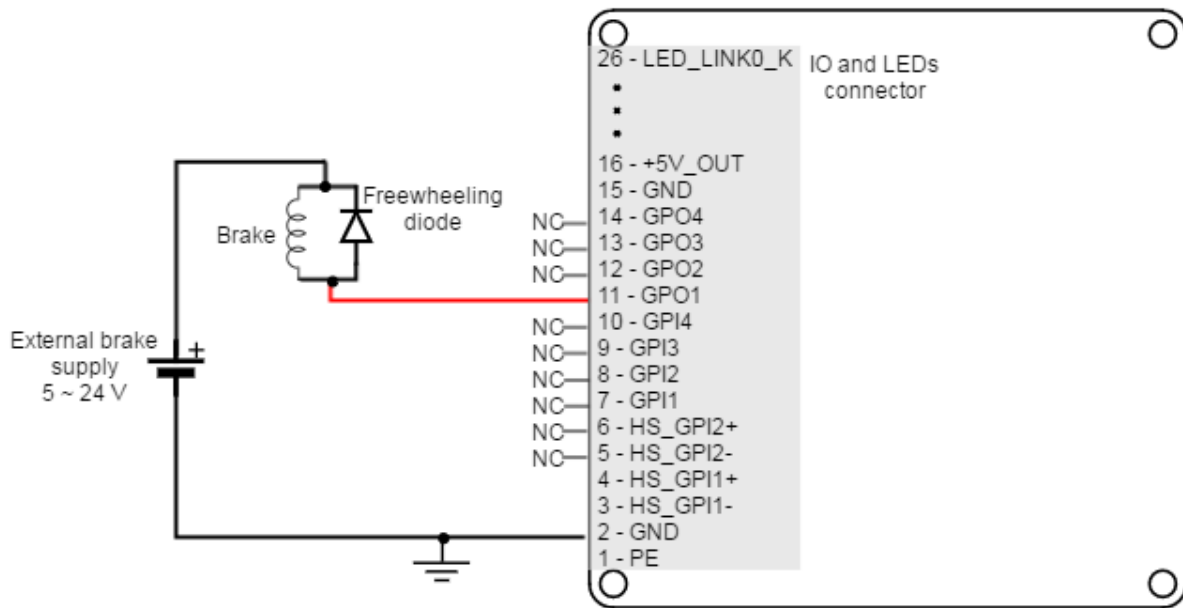

**Free-wheeling diode**

It is recommended to use a freewheeling diode in anti-parallel with the brake to prevent inductive kicking (voltage rise when current through the brake inductance falls to zero). Standard rectifier diodes such as 1N4002<sup>74</sup> or 1N4934<sup>75</sup> are appropriated for the application.

**7.5.6 Motor temperature input (MOTOR\_TEMP)**

The Triton Go has a dedicated analog input for measuring the motor temperature, which can be found in the [Halls, motor temperature and analog feedback connector](#). (see page 23) The motor temperature input is connected to the internal analog input 3 and allows the connection of an external temperature sensor (PTC thermistor, bimetal, NTC) to measure the motor temperature.

This analog input includes a 967 Ω pull-up for directly connecting a PTC thermistor. An example of temperature sensor wiring is shown in the following figure:

<sup>74</sup> [http://www.onsemi.com/pub\\_link/Collateral/1N4001-D.PDF](http://www.onsemi.com/pub_link/Collateral/1N4001-D.PDF)

<sup>75</sup> <http://www.vishay.com/docs/88508/1n4933.pdf>

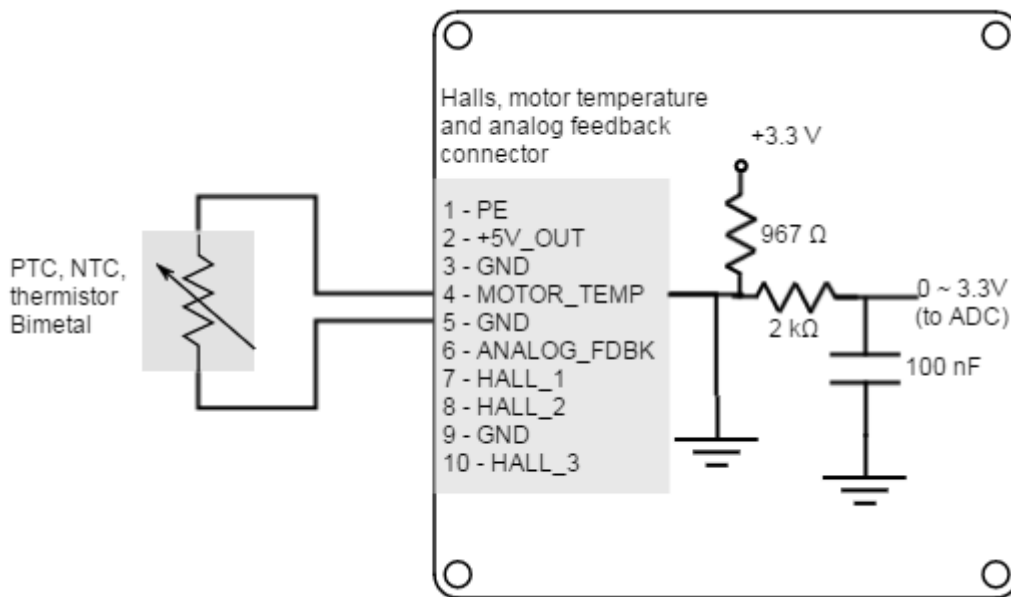

**i Suggested PTC**

The suggested PTC thermistor value is a 1 kΩ nominal resistance (@ 25 °C) as Vishay PTC (TFPTL10L1001FL2B<sup>76</sup>).

Main specifications of the external temperature sensor input are shown in the next table:

Specification	Value
Type of input	Single ended analog 967 Ω pull-up resistor
Mapping	Analog input 3 (AN_IN3)
1st order low-pass filter cutting frequency (-3dB)	800 Hz

### 7.6 Command sources

The target or command sources are used for setting a reference for position, velocity or torque controllers. Triton Go Servo Drive supports the following command sources:

- [Network communication interface](#) (see page 97) (USB, CANOpen, RS-485 or EtherCAT)
- [Standalone](#) (see page 97)
- [Analog input](#) (see page 98) (±10 V or 0 V to 5 V)
- [Step and direction](#) (see page 99)
- [PWM command](#) (see page 100) (single and dual input mode)

<sup>76</sup> <http://www.vishay.com/docs/33027/tfptl.pdf>



- [Encoder follower / electronic gearing](#) (see page 103).

Analog inputs, step and direction, PWM command and encoder follower / electronic gearing are interfaced through general purpose inputs. Next table illustrates which variables can be controlled with each command source:

Command source	Target variable
Network interface	Position, velocity, torque
Standalone	Position, velocity, torque
Analog input (+/- 10 V o 0 – 5 V)	Position, velocity, torque
Step and direction	Position
PWM command	Position, velocity, torque
Encoder following / electronic gearing	Position

Please, see [Command sources](#)<sup>77</sup> section from [E-Core](#)<sup>78</sup> documentation for configuration details.

### 7.6.1 Network communication interface

Triton Go Servo Drive can utilize network communication as a form of input command. Supported network interfaces for Triton Go Servo drive are CAN (CANopen protocol), USB, RS-485 and EtherCAT.

USB interface is not suitable for long distances or noisy environments. This protocol is only recommended for configuration purposes.

For normal operation, it is suggested to use CAN, RS-485 or EtherCAT. These interfaces are more robust against noise than USB, and allow higher distances between the Triton Go Servo Drive and the commander. These command sources can be used for setting position, velocity or torque target.

For further information, see [Communications section](#) (see page 104).

### 7.6.2 Standalone

Triton Go Servo Drive is provided with an internal non-volatile memory where a standalone program can be saved. With the use of Ingenia [Motion Lab](#)<sup>79</sup> suite, the user can configure and save instructions to this 1 Mb (128K x 8bit) EEPROM, allowing Triton Go Servo Drive to work in standalone mode. In this mode, there is no need of any external command source.

Programs or macros composed with Motion Lab suite allow to **configure position, velocity or torque targets** and to **interface with general purpose inputs and outputs**.

<sup>77</sup> <http://doc.ingeniamc.com/display/EMCL/Command+Sources>

<sup>78</sup> <http://doc.ingeniamc.com/display/EMCL/Command+Reference+Manual>

<sup>79</sup> <http://ingeniamc.com/software#motionlab>

This feature can be very useful in applications such as production lines or test equipment, where repetitive movements are usual. Please refer to [MotionLab documentation](#)<sup>80</sup> for further information.

### 7.6.3 Analog input

Position, velocity or torque targets can also be controlled through an analog signal. Any general purpose analog input can be used as command source. Triton Go Servo Drive has two 12-bit analog inputs, a single ended one with 0 V to 5 V range (AN\_IN1) and a differential one with +/-10 V range (AN\_IN2). Refer to [I/O Connections](#) (see page 79) for further details about analog inputs.

A common application of the analog command source is the use of joysticks (or other kinds of potentiometers) for controlling the position or velocity of a system. As application examples, the following figures show how to connect a potentiometer to the single ended analog input (AN\_IN1) and a dual track potentiometer to the differential analog input (AN\_IN2).

As an application example, the next picture shows how to connect a dual track potentiometer to get a ±10 V differential input.

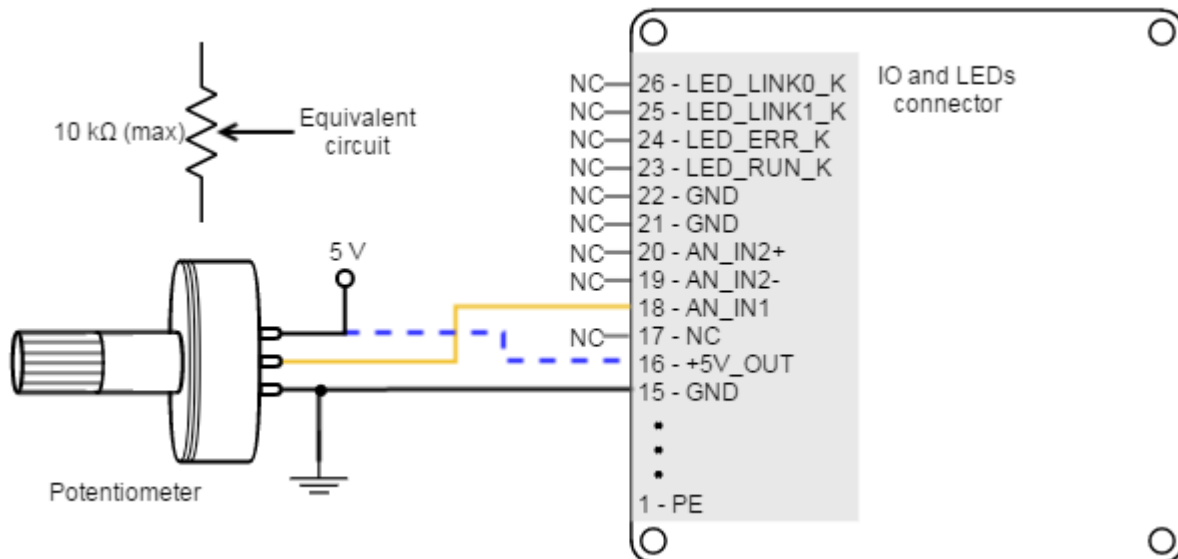

<sup>80</sup> <http://doc.ingeniamc.com/display/i02201/User+Manual>

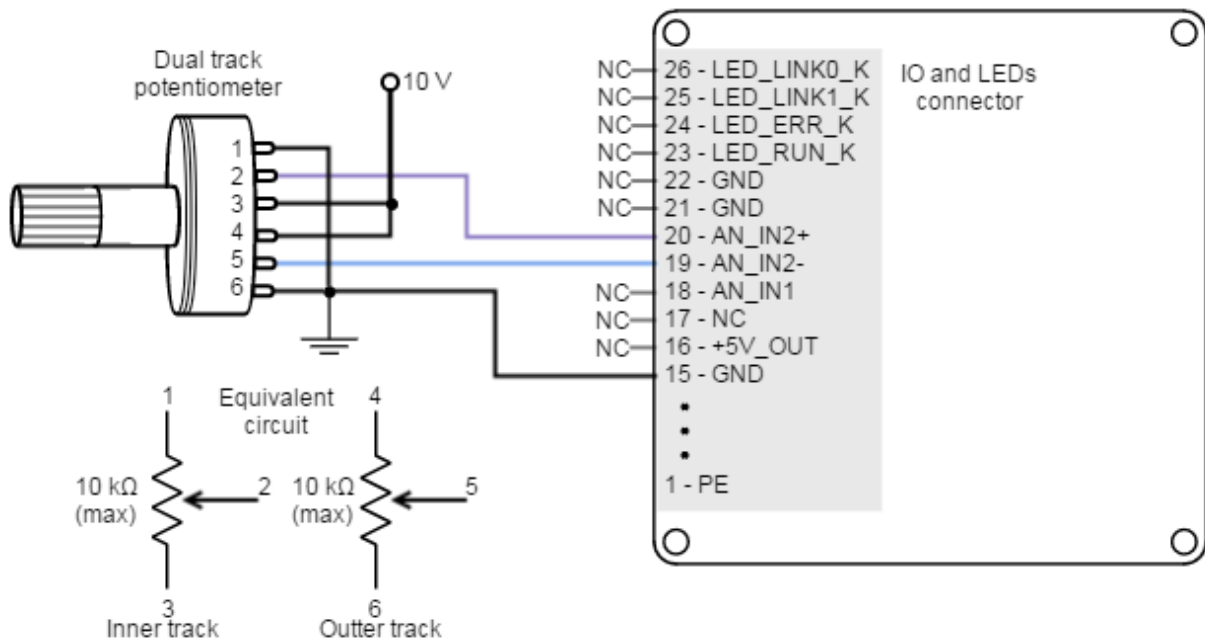

### 7.6.4 Step and direction

For this command source, the drive typically accepts two digital inputs from an external source: Step (pulse) and Direction. Direction signal sets the direction of rotation (i.e., logic low or "0" for clockwise rotation and logic high or "1" for counter-clockwise rotation). Pulse signal is usually a square signal and each pulse on this signal causes the controller to move the motor one step in that direction. This command source can be used only for position mode.

This command source is interfaced through high-speed digital inputs. HS\_GPI1 is used for Step input, and HS\_GPI2 is used for Direction input. Refer to [I/O Connections](#) (see page 79) for further specifications about high-speed digital inputs. Next figures illustrate how to connect a single ended and differential step and direction command source to the Triton Go Servo Drive.

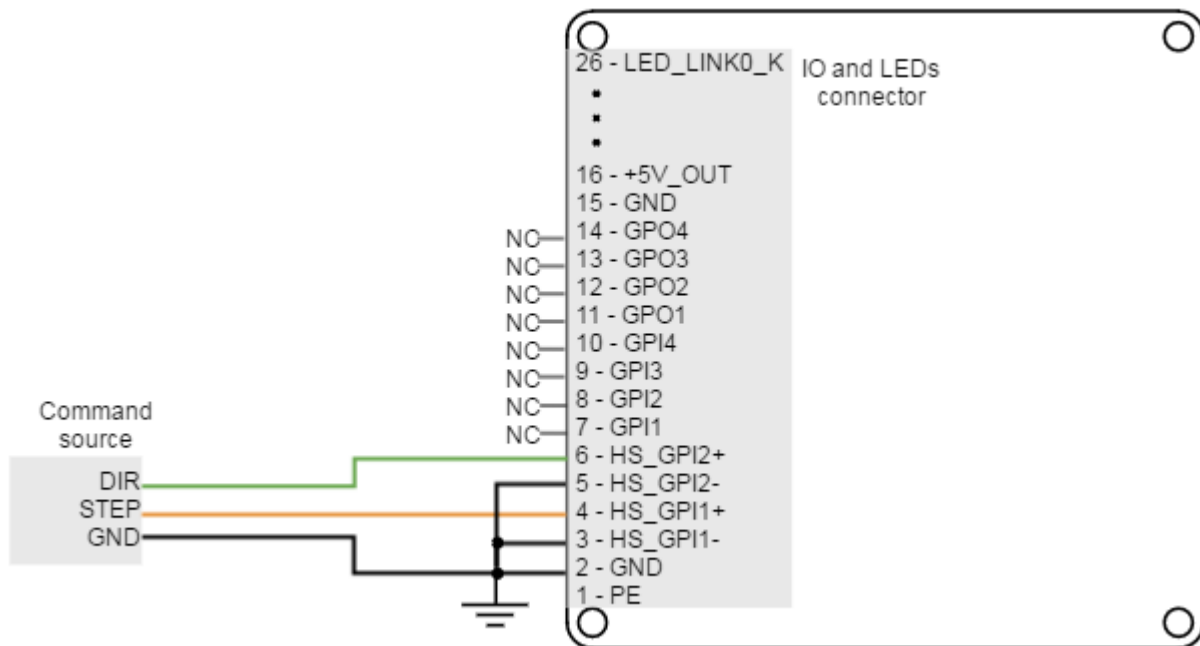
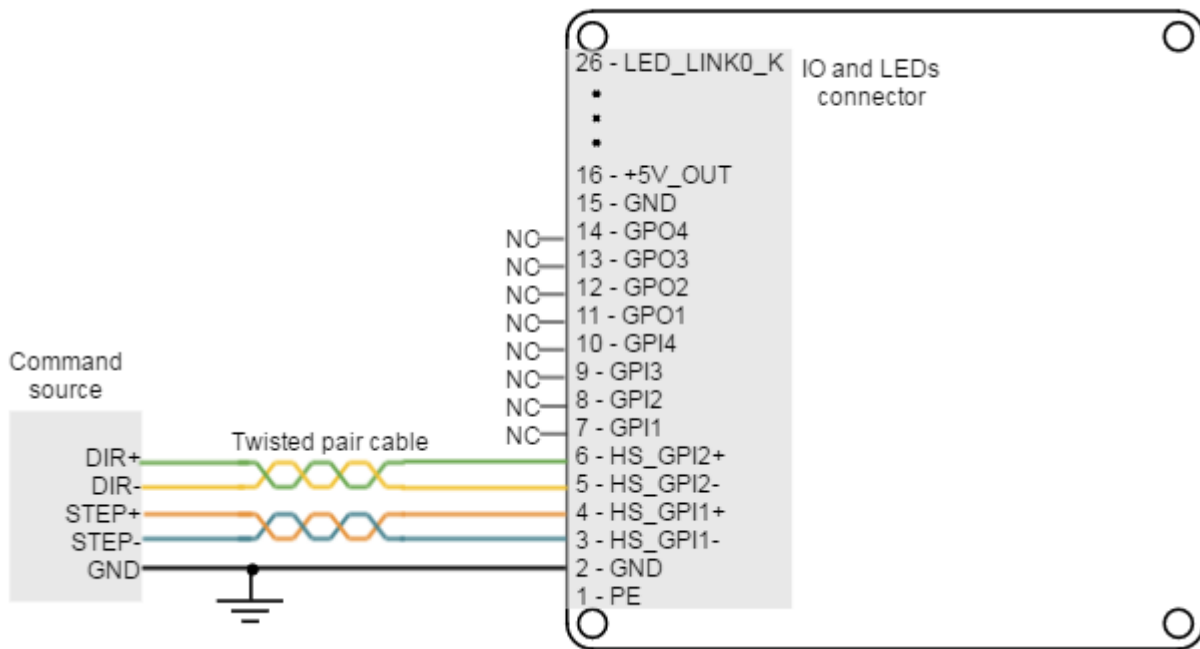

### 7.6.5 PWM command

PWM command source sets a position, velocity or torque target from the duty cycle value of a PWM signal. PWM command has to be interfaced with the **high-speed digital input 2 (HS\_GPI2)**. Further details about this input can be seen in [I/O Connections](#) (see page 79) page. PWM command sources with single and dual input modes can be used.

### Single input mode

Single input mode is based on the use of a PWM signal whose duty cycle sets the target position, velocity or torque. A duty cycle of 50% corresponds with a target of 0 rad, 0 rpm or 0 N·m, and higher or lower values indicate the target in a different rotating direction. That is, a duty cycle of 0% corresponds with the maximum position, velocity or torque in one direction, and a 100% duty cycle corresponds to the maximum position, velocity or torque in the opposite direction.

Examples of single input mode PWM command in differential and single ended connections are shown in the next figures.

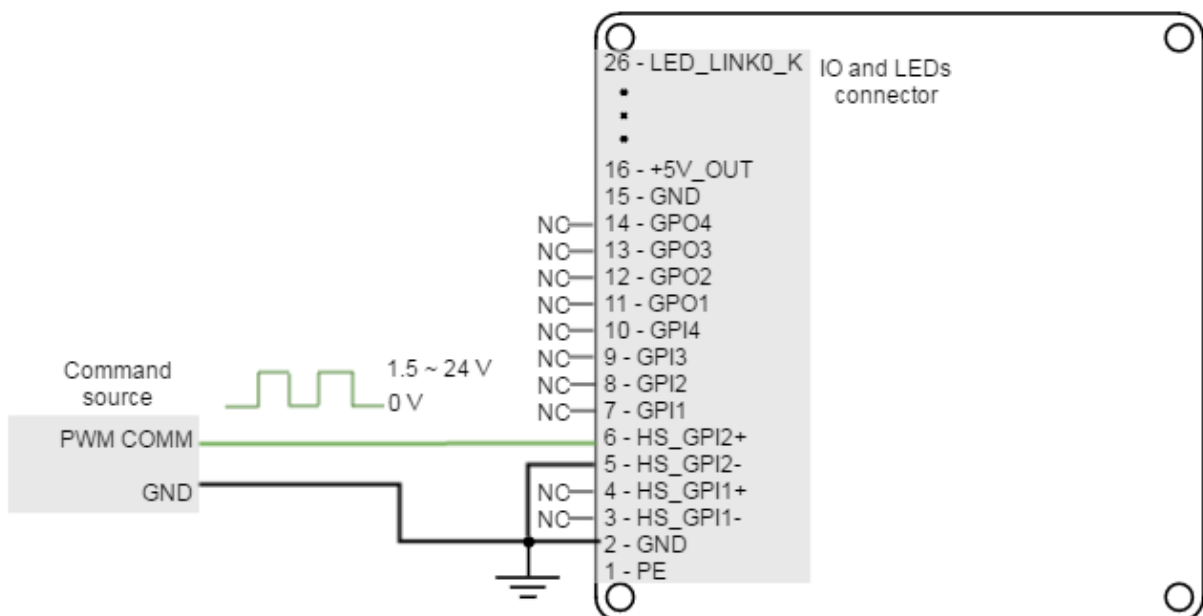
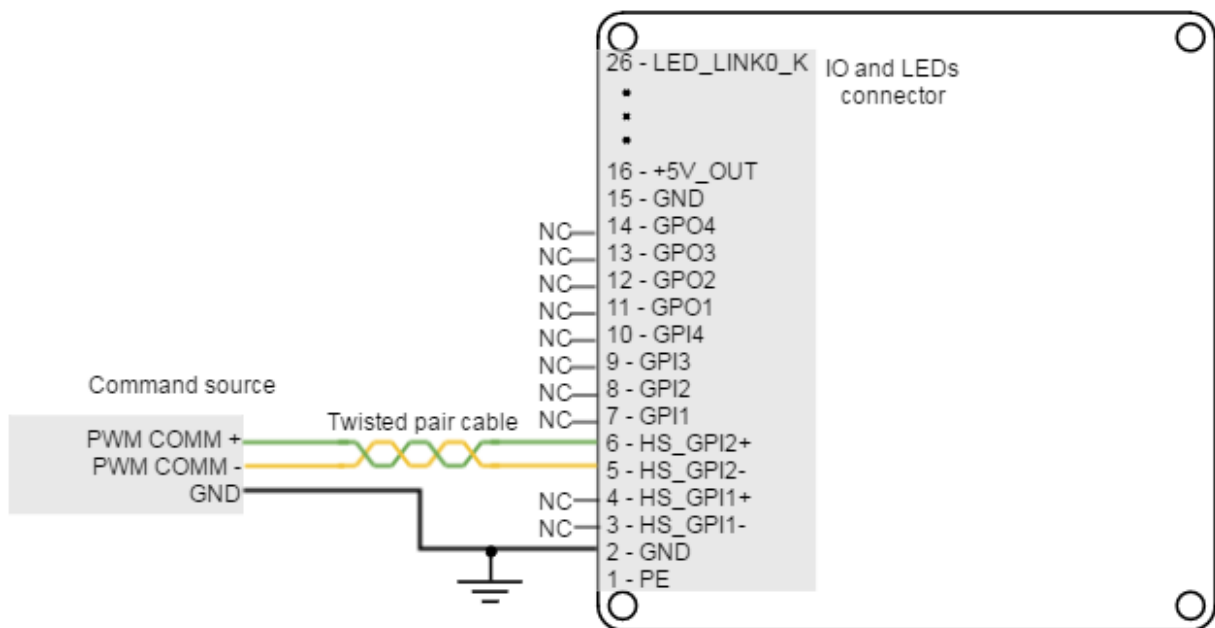

**Dual input mode**

Dual input mode uses two signal lines, a PWM signal whose duty cycle sets the target position, velocity or torque, and a Direction signal that indicates the rotation direction (i.e., logic low or "0" for clockwise rotation and logic high or "1" for counter-clockwise rotation). In this mode, a duty cycle of 0% corresponds with a target of 0 rad, 0 rpm or 0 N·m, and a duty cycle of 100% corresponds to the maximum position, velocity or torque.

Two general purpose inputs are used:

- High speed digital input 2 (HS\_GPI2) for PWM Command
- General purpose digital input 1 (GPI1) for Direction.

Examples of dual input mode PWM command in differential and single ended connections are shown in the next figures.

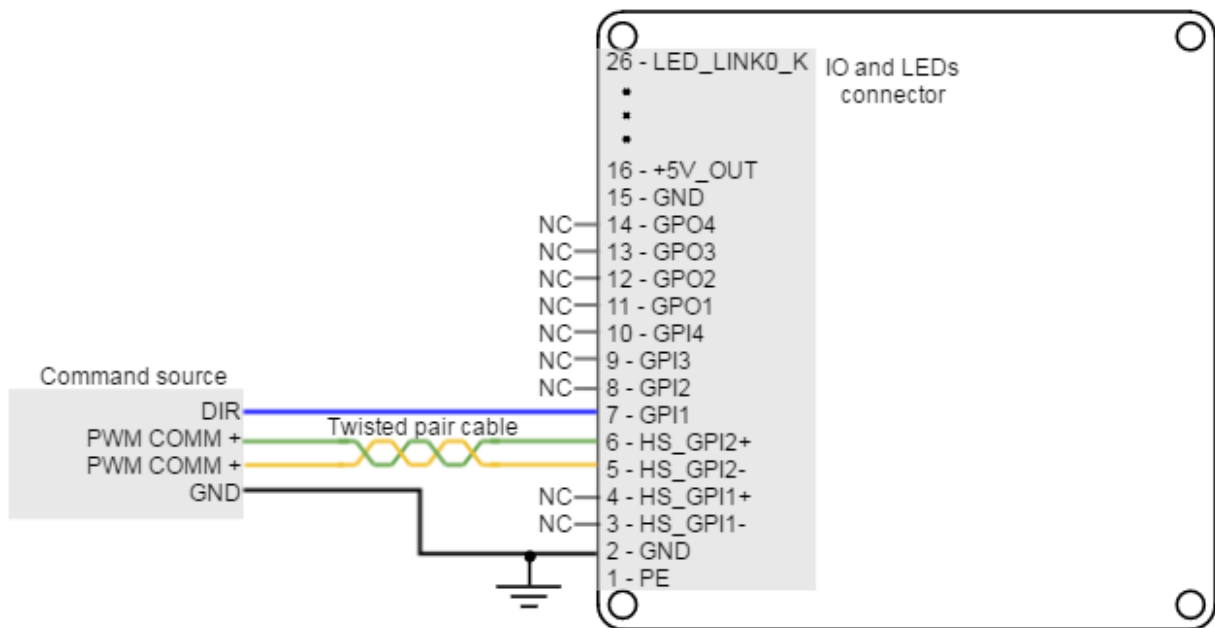

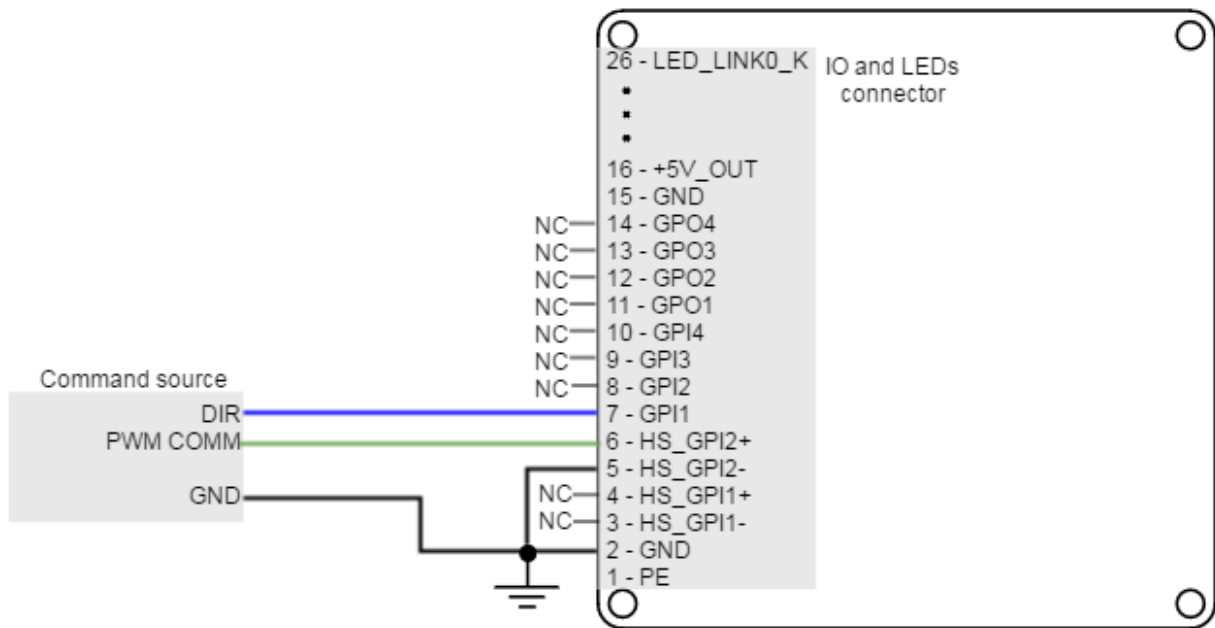

### 7.6.6 Encoder following or electronic gearing

Encoder following command source is used for **drive two motors to the same position**. The encoder (or an auxiliary encoder) of the master motor is read by the Triton Go Servo Drive and used as position target. A gearing ratio between the motors (input counts to output counts ratio) can be configured via software.

Encoder following command source is implemented by connecting the input encoder (auxiliary encoder of the master motor) to high-speed digital inputs (HS\_GPI). Encoder channel A must be connected to high speed digital input 1, and channel B to high speed digital input 2. Connection examples for the differential and single ended master encoders are shown in the next figures:

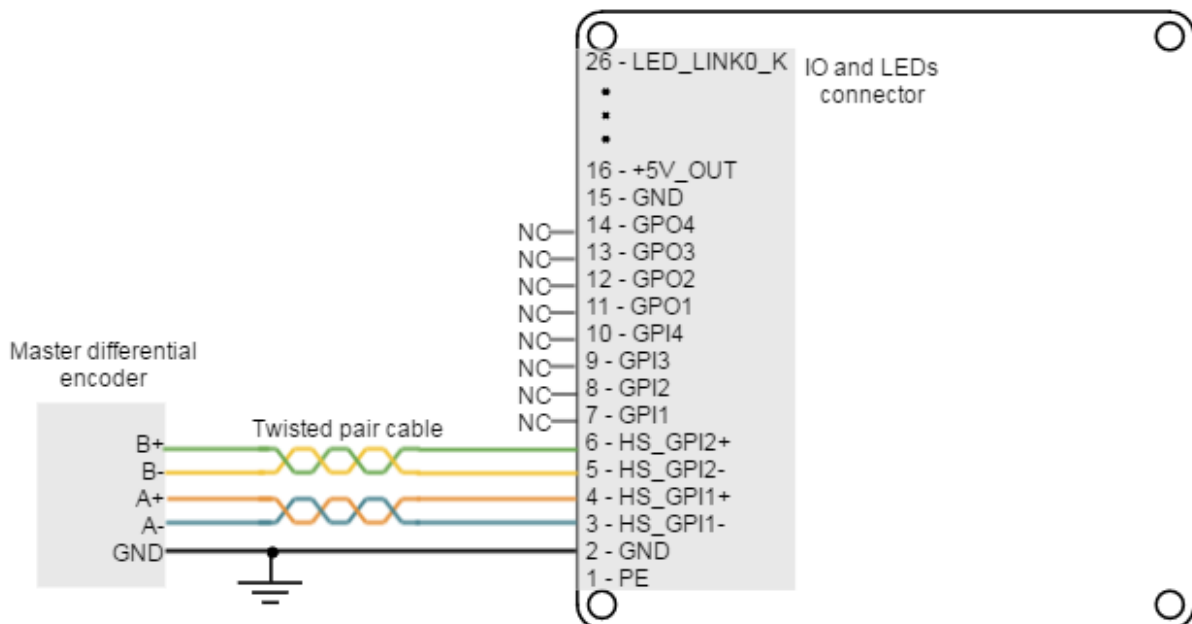

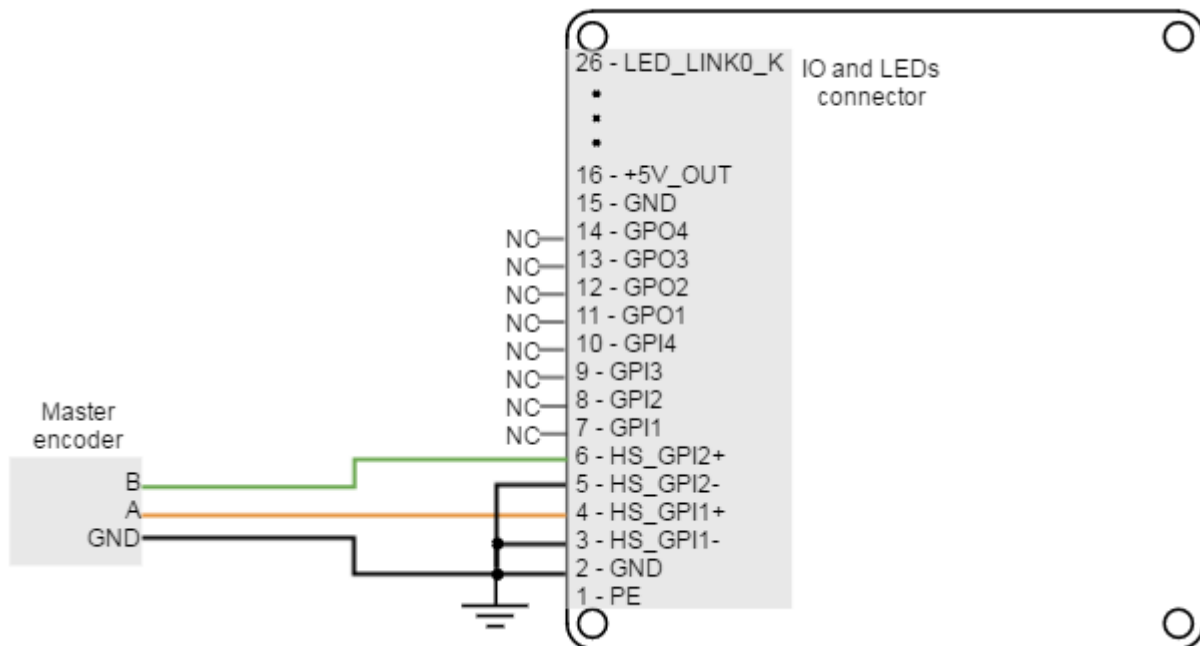

## 7.7 Communications

The Triton Go Servo Drive provides the following network communication interfaces for configuration and operation:

- [USB](#) (see page 104)
- [Serial interface - RS485](#) (see page 105)
- [CANopen](#) (see page 107)
- [EtherCAT](#) (see page 110)

All the interfaces can be used to connect the Triton Go with Ingenia **Motion Lab**<sup>81</sup> suite or a custom application built with the supplied controller libraries. With the objective of configure and diagnostic CAN communication, CANopen and another communication interface can be used simultaneously.

### 7.7.1 USB interface

Triton Go Servo Drive supports Universal Serial Bus (USB), a standard interface for connecting peripheral devices to a host computer. The following table shows main USB interface specifications:

Specification	Details
USB version	USB 2.0 (full speed)
Data rate	Up to 12 Mbps

<sup>81</sup><http://ingeniamc.com/software#motionlab>



Maximum cable length	5 meters (16 feet)
----------------------	--------------------

### ✔ **USB application**

USB interface is only recommended for configuration purposes. For noisy environments, CANopen interface is strongly recommended.

## **USB powered drive**

**The Triton Go can be powered from USB for configuration purposes** without the need of an external power supply. With USB supply the Triton Go is not capable of driving a motor, but communications, feedbacks and IOs are fully functional. An internal switch automatically chooses the power source prioritizing the Supply and shunt connector. Please note that several functionalities will not be available when powered from USB.

## **USB wiring recommendations**

Although USB is a widespread communication standard it has some disadvantages when operating in noisy environments. Following are some wiring recommendations.

- Use shielded cable with the shield connected to PC end. Shield of micro USB connector is **not** connected on Triton Go.
- Do not rely on an earthed PC to provide the Triton Go Servo Drive earth connection. The drive must be earthed through a separate circuit.
- Avoid creating ground loops by using isolated power supplies.
- Shortest cables are preferred.

### **7.7.2 RS485 interface**

Triton Go Servo Drive supports **full duplex RS-485**. This means that independent differential lines are used for TX and RX, which cannot be connected together. **Full-duplex RS485 is fully compatible with RS422 communication.**

### **i Multi-point connection**

Triton Go Servo Drive RS485 interface is not intended for bus operation, since there is no collision prevention protocol implemented. However, **multiple drives can be connected to the same master using daisy chain connection.**

Multiple drive connection with daisy chain **must be configured using Ingenia Motion Lab<sup>82</sup> suite.** For allowing multi-point communication **each servo drive must be allocated a unique node ID**, and **daisy chain option must be enabled.** Please, see [UART configuration<sup>83</sup>](#) section in [E-Core<sup>84</sup>](#) documentation for further information.

<sup>82</sup> <http://ingeniamc.com/software#motionlab>

<sup>83</sup> <http://doc.ingeniamc.com/display/EMCL/0x2000+-+UART+configuration>

<sup>84</sup> <http://doc.ingeniamc.com/display/EMCL/Command+Reference+Manual>

Main specifications of Triton Go RS485 interface are shown in the next table:

Specification	Details
Interface	Full duplex Non-isolated Self-supplied (no need for external supply)
Communication distance	Up to 1200 m
Baud rate	128 kbps to 460 kbps
Daisy chain	Supported
Termination resistor	120 Ω termination resistor on RX channel

Next figure illustrates how to connect Triton Go Servo Drive with a host in a point to point configuration.

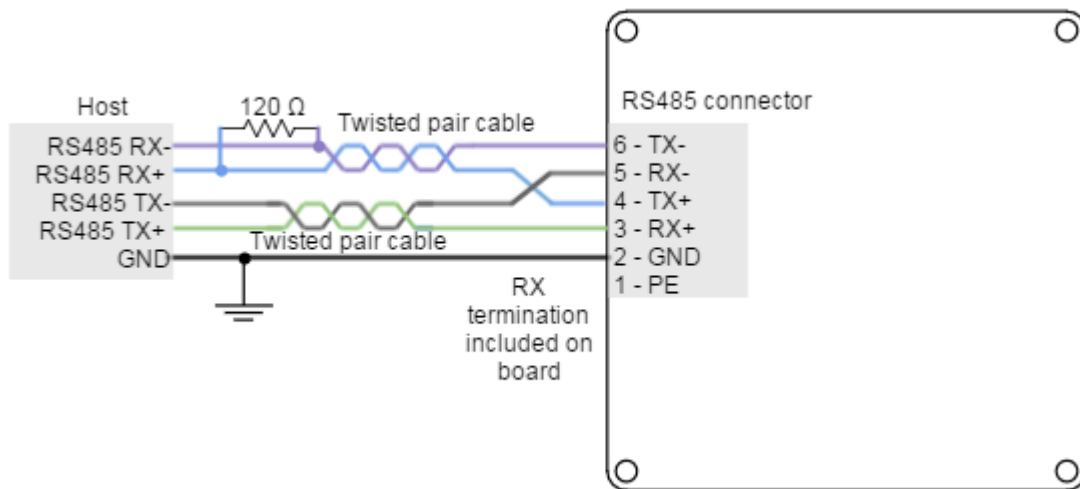

**⚠ Termination resistor**

The use of **termination resistors at the RX side** of each differential pair (120 Ω between RX+ and RX- of both host and slave) is essential for correct operation of the RS485 communication. **For long cable distances (> 10 m) a termination in the TX side** is also recommended.

**Triton Go Servo Drive includes a RX termination resistor on board.** Another 120 Ω termination resistor should be placed at the end of Triton Go TX line (RX of the host). Suggested termination resistor: Xicon [271-120-RC](http://www.mouser.com/ProductDetail/Xicon/271-120-RC?qs=sGAEpiMZZMsPqMdJzcrNwviByDyk9Y2oQeQ7BxU4xro%3d)<sup>85</sup>.

<sup>85</sup> <http://www.mouser.com/ProductDetail/Xicon/271-120-RC?qs=sGAEpiMZZMsPqMdJzcrNwviByDyk9Y2oQeQ7BxU4xro%3d>

### Multi-point connection using daisy chain

Daisy chain connection is a multi-point network topology based on connecting multiple terminals in a ring. The wiring consists on connecting the TX terminals of each device to the RX terminals of the next device. An example of daisy chain wiring of multiple Triton Go is shown in the next figure.

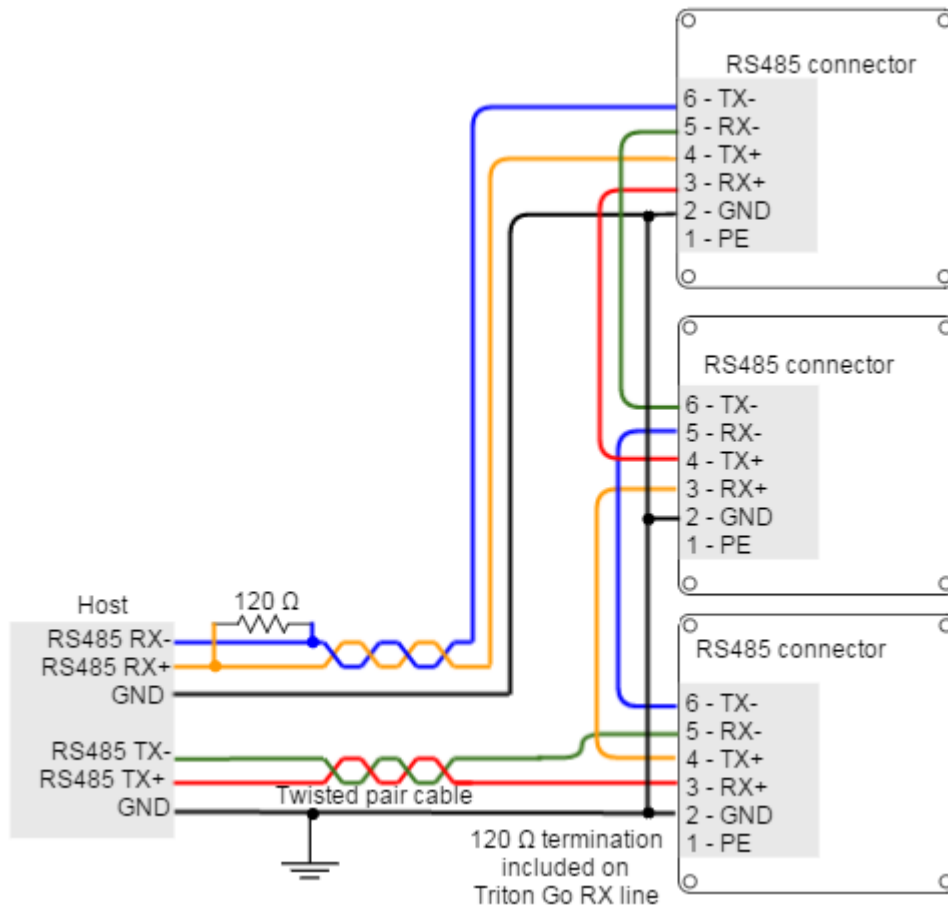

#### **⚠ Termination resistor for daisy chain**

In daisy chain connection, **termination resistors are required in each link**. For short distances, a 120 Ω termination resistor in the RX side is required. For long distances (> 10 m) it is required in RX and TX sides.

Triton Go includes a termination on the RX line (activated through a jumper) allowing direct daisy chain wiring for short links.

### 7.7.3 CANopen interface

Triton Go Servo Drive with CAN (TRI-x/xx-C-C) provides access to the CANopen interface, a multi-terminal communication protocol based on CAN (Controller Area Network) bus. Triton Go CAN interface is isolated, and self-supplied. Main physical specifications are shown in the next table:

Specification	Details
Interface	Non-isolated. Self-supplied (no need for external supply)
Baud rate	From 125 kbps to 1 Mbps (default value)
Maximum number of nodes	64
Common mode voltage	Up to 36 V
Termination resistor	120 $\Omega$ on board (externally connect CAN_TERM to CAN_L to enable)

#### Drive ID

When installing CANopen communication, ensure that each servo drive is allocated a unique ID. Otherwise, CANopen network may hang.

#### CAN GND connection

GND line in CAN devices is used for equaling potential between master and slaves, but is not used for data transmission, as the line is fully differential. For this reason, if the **host device shares supply GND with Triton Go it is not needed to connect CAN connector GND again**, as this could cause ground loop issues.

Since Triton Go has two CAN connectors, wiring from previous device and to next device can be done using different connectors (CAN IN and CAN OUT). **Pins 2, 3 and 4 of those connectors are connected pin-to-pin.** The unique difference is in pin 1, which is not connected in CAN IN and connected to the termination resistor in CAN\_OUT. An example of CAN wiring is shown in the next figure.

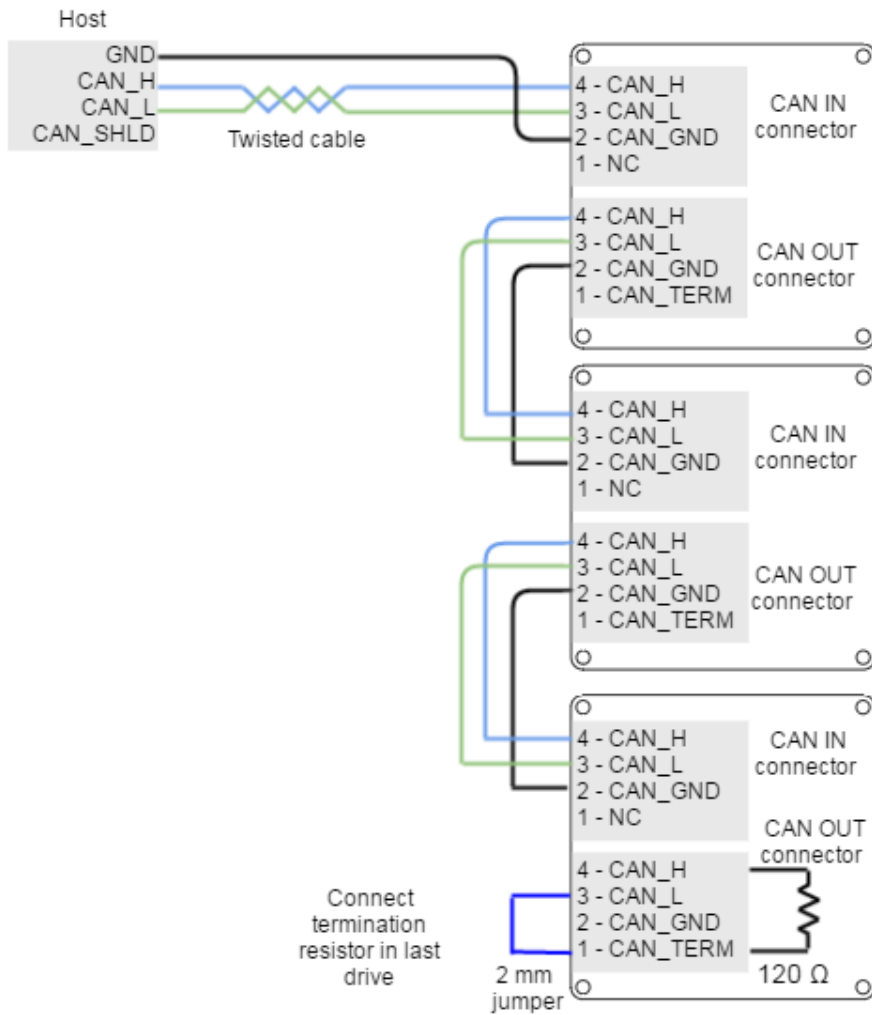

### **⚠ Termination resistor**

The use of bus termination resistors (120  $\Omega$  between CAN\_L and CAN\_H), one at each end of the bus, is essential for correct operation of the CAN bus. Even with only one Triton Go connected, mount the termination resistor to ensure CAN bus operation. **Do not use wirewound resistors**, which are inductive.

**Triton Go Servo Drive includes a termination resistor on board.** The resistor is connected between CAN\_H and CAN\_TERM. To activate the resistor, connect pins 1 (CAN\_TERM) and 3 (CAN\_L) on CAN OUT connector. The connection can be done with a standard 2 mm pitch jumper.





### **✔ CAN GND connection**

GND line in CAN devices is used for equaling potential between master and slaves, but is not used for data transmission, as the line is fully differential. For this reason, if the **host device shares supply GND with Triton Go it is not needed to connect CAN connector GND again**, as this could cause ground loop issues.

### CAN interface for PC

The Ingenia **Motion Lab**<sup>86</sup> suite is able to communicate with the Triton Go Servo Drive through CANopen interface. For this purpose, a CAN transceiver for PC is required. Motion Lab is compatible with the following CAN transceivers: Kvaser, Peak-System, IXXAT, Vector and Lawicel.

Some recommended CAN transceivers are shown below:

Manufacturer	Part Number	Image	Description
Peak-system	PCAN-USB opto-decoupled (IPEH-002022)		<ul style="list-style-type: none"> <li>• USB to CAN single channel interface with 9-pin D-SUB CAN connector.</li> <li>• Enables simple connection to CAN networks.</li> <li>• Opto-decoupled with galvanic isolation of up to 500 Volts between the PC and the CAN side.</li> </ul>
Kvaser	USBcan Pro 2xHS v2		<ul style="list-style-type: none"> <li>• USB to CAN or CAN FD dual channel interface.</li> <li>• High-speed CAN channels in two separate 9-pin D-SUB CAN connectors.</li> </ul>
IXXAT	USB-to-CAN V2 Professional		<ul style="list-style-type: none"> <li>• USB to CAN dual channel interface.</li> <li>• High-speed CAN channels in two separate RJ-45 connectors.</li> <li>• Cable adapter to 9-pin D-SUB CAN.</li> </ul>
Vector Informatik	VN1630		<ul style="list-style-type: none"> <li>• USB to CAN or CAN FD four channel (two connectors) interface .</li> <li>• High-speed CAN channels in two separate 9-pin D-SUB CAN connectors.</li> <li>• Highly robust plastic housing.</li> </ul>

### CAN wiring recommendations

- Build CAN network using cables with **2-pairs of twisted wires** (2 wires/pair) as follows: one pair for CAN\_H with CAN\_L and the other pair for CAN\_V+ with CAN\_GND.
- Cable impedance must be of 105 to 135 Ω (120 Ω typical) and a capacitance below 30 pF/meter.
- Whenever possible, use bus links between the CAN nodes. **Avoid using stubs** (a "T" connection, where a derivation is taken from the main bus). If stubs cannot be avoided keep them as short as possible. For maximum speed (1 Mbps), use a stub length lower than 0.3 meters.
- For a total CAN bus length **over 40 meters**, it is mandatory to **use shielded twisted cables**. Connect the cable shield to protective earth at both ends. Ensure that the cable shield is connected to the connector shield, as connection to host protective earth is usually soldered inside the connector.

<sup>86</sup> <http://ingeniamc.com/software#motionlab>

### 7.7.4 EtherCAT interface

Triton Go Servo Drive with EtherCAT (TRI-x/xx-E-C) variant provides access to the EtherCAT fieldbus system. EtherCAT is an isolated bus suitable for hard and soft real-time requirements in automation technology, test and measurement and many other applications.

Next table summarizes the features of the Triton Go EtherCAT interface.

EtherCAT specific features	
<b>Ports available</b>	2
<b>LED Signals</b>	Status LED
	Link/Act LED
<b>Supported Mailbox</b>	CoE
<i>SDO info</i>	Not supported
<i>Segmented SDO</i>	Supported
<i>SDO complete access</i>	Not supported
<b>Synchronization modes</b>	Free Run
	Distributed clock ( <i>Cyclic modes</i> )
<b>Process data object</b>	Configurable, up to 64 objects

Next figure shows a wiring diagram of an EtherCAT bus.

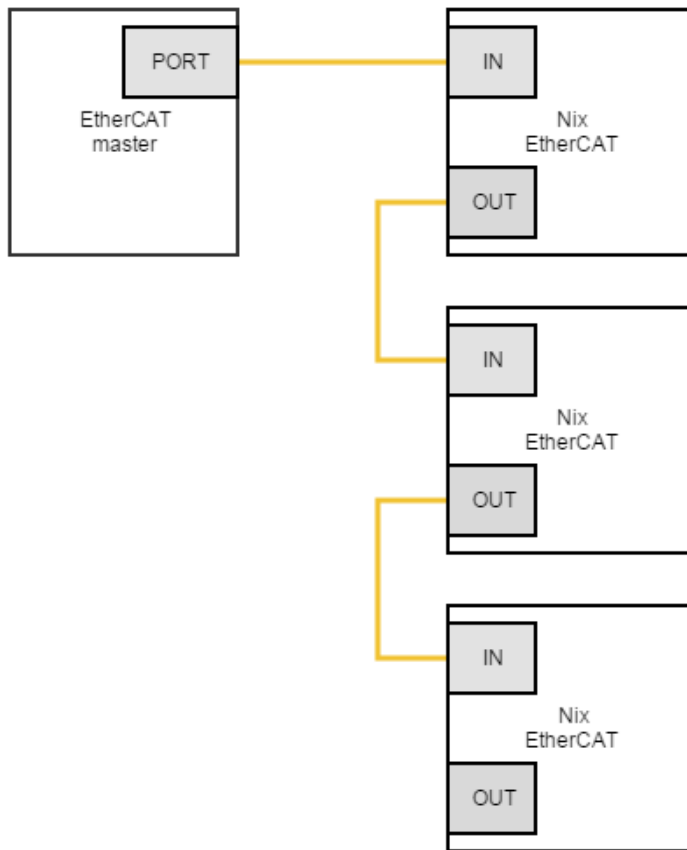

### 7.8 Safe Torque Off (STO)

Triton Go Servo Drive includes a Safe Torque Off (STO) connector. **The STO is a safety system that prevents motor torque in an emergency event** while Triton Go remains connected to the power supply. When STO is activated, the power stage is disabled automatically (no matter what control or firmware does), and the motor shaft will slow down until it stops under its own inertia and frictional forces.

The Triton Go STO works with negative logic, deactivating the power stage by default. **In order to activate the power stage**, and therefore allow the motor operation, **two differential inputs must energized**. These inputs activate two optocouplers connected in series that enable the Triton Go power stage operation. On the contrary, **if the STO inputs are not energized, the transistors of the power stage are turned off** and a STO fault is notified. During this state, no torque will be applied to the motor no matter configuration, or state of a command source. This will slow down the motor shaft until it stops under its own inertia and frictional forces. This input should not be confused with a digital input configured as enable input, because enable input is firmware controlled and does not guarantee intrinsic safety as it can be reconfigured by a user.



**i STO firmware notification**

An STO stop is notified to the control DSP and creates a **fault**<sup>87</sup> that can be read externally, however its performance is totally independent from control or firmware. When the STO is not connected it is virtually impossible to apply power to the drive.

STO inputs have an input voltage range from +4.5 V to +36 V. In order to simplify the wiring, the STO connector includes two 5V pins and a GND pin. Next figures shows how to connect the STO inputs with an external power supply, and with the self 5V\_OUT pins.

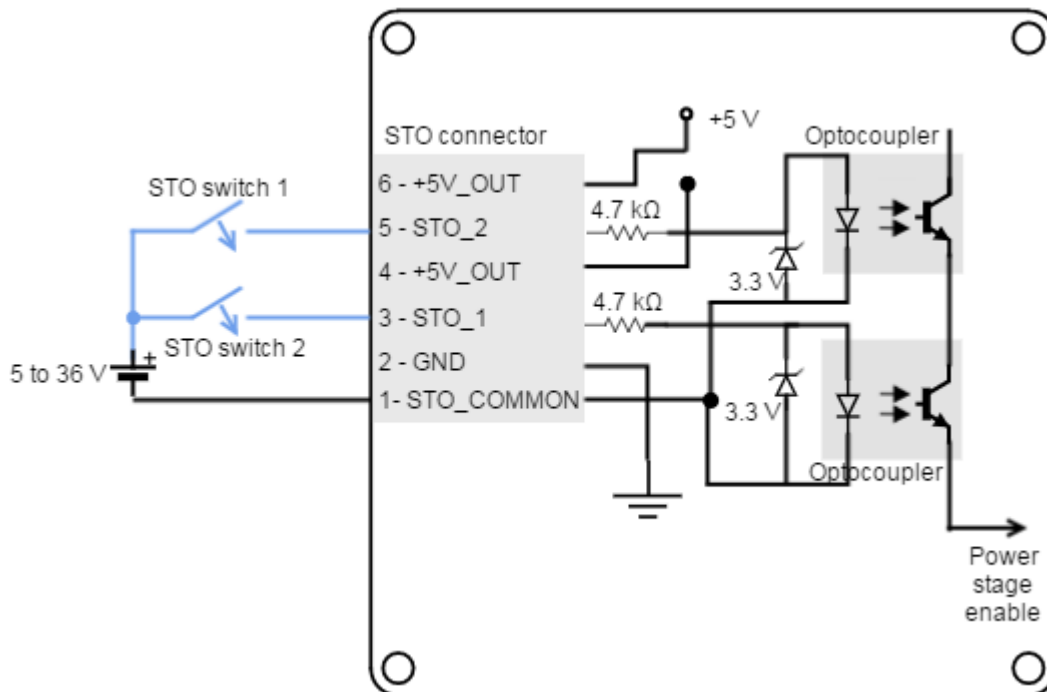

<sup>87</sup> <http://doc.ingeniamc.com/display/EMCL/Error+management>

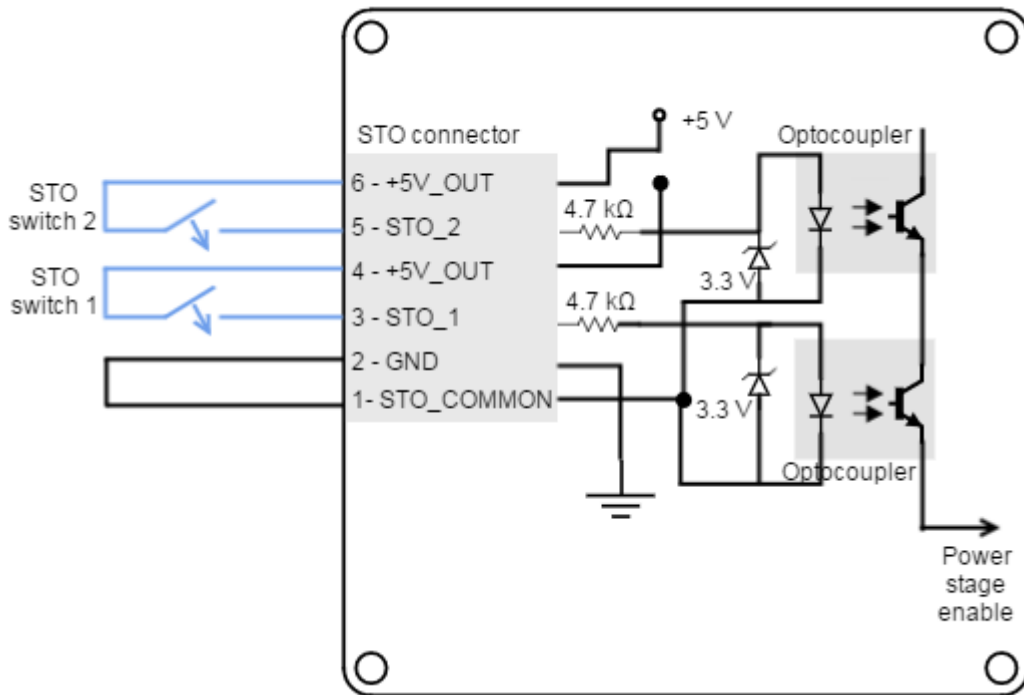

**✔ Overriding STO**

In applications where the STO will not be used, this function can be disabled with the use of three standard 2 mm jumpers. The connection of pins 1-2, 3-4 and 5-6 will activate the optocouplers and enable the power stage operation.

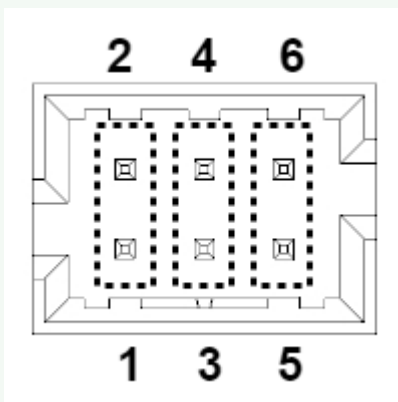

## 8 Dimensions

The Triton Go Servo Drive is available in 2 versions with different dimensions: TRI-x/48-C-C (Triton Go with CAN) and TRI-x/48-C-E (Triton Go with EtherCAT). Both have a **43 mm x 45 mm footprint, 23.5 mm height** and 4 x  $\varnothing$  3.3 mm holes in a 37 mm x 37 mm square for **M3 screws** mounting.

**⚠ Thermal dissipation required**

To reach its power specifications, most Triton Go variants must be mounted over a **metallic chassis or heatsink**, and a thermal interface material must be placed and compressed in between.

### 8.1 Triton Go with CAN (TRI-x/48-C-C)

All dimensions are in **mm**. All tolerances  $\leq \pm 0.2$  mm.

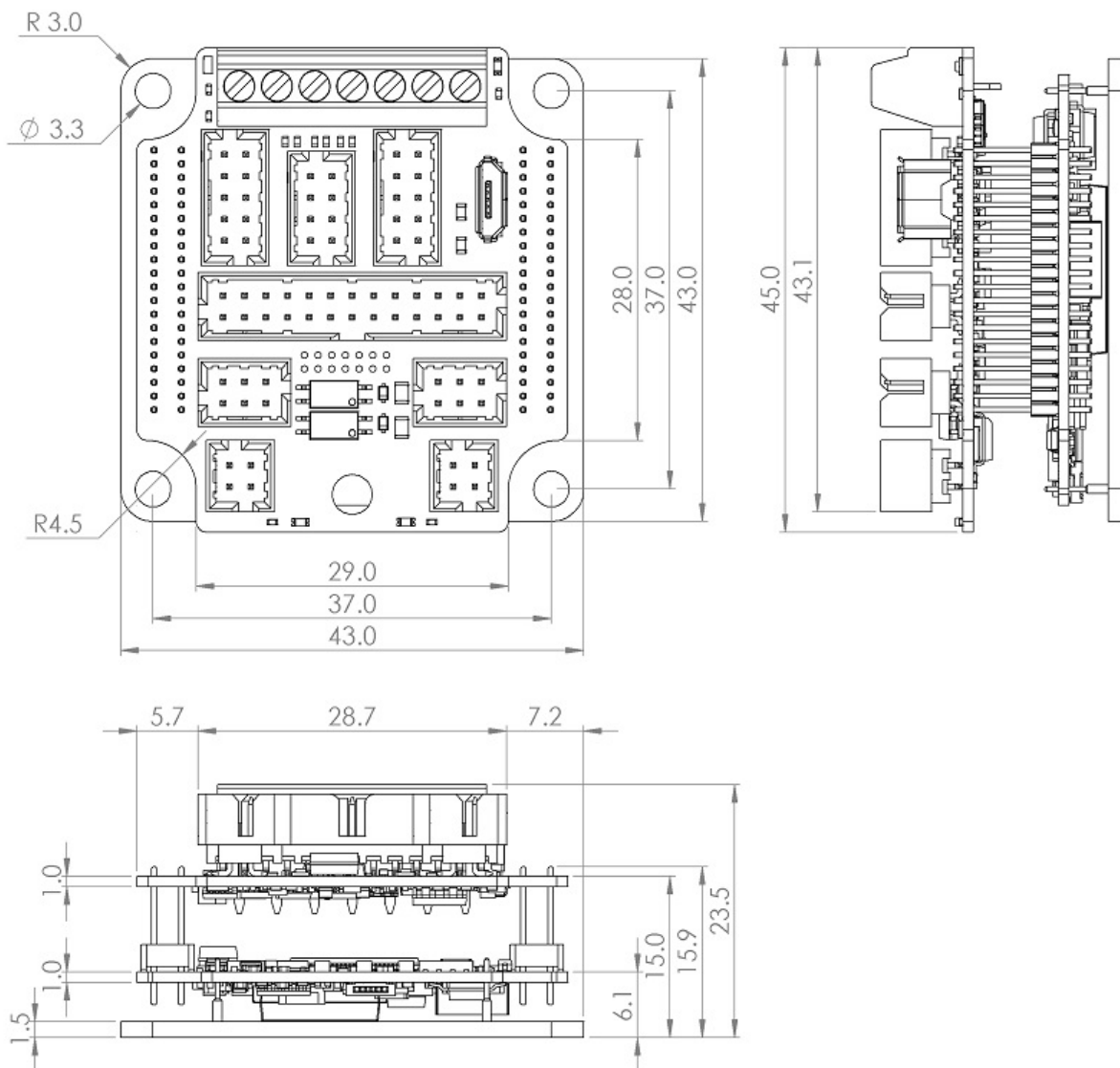

**i 3D Model**

For further detail, download the [STEP 3D model](#) and [PDF 3D<sup>88</sup>](#) for this variant. Note that the model is simplified: it does not show all the internal components, but does show the major volumes.

**8.2 Triton Go with EtherCAT (TRI-x/48-E-C)**

All dimensions are in **mm**. All tolerances  $\leq \pm 0.2$  mm.

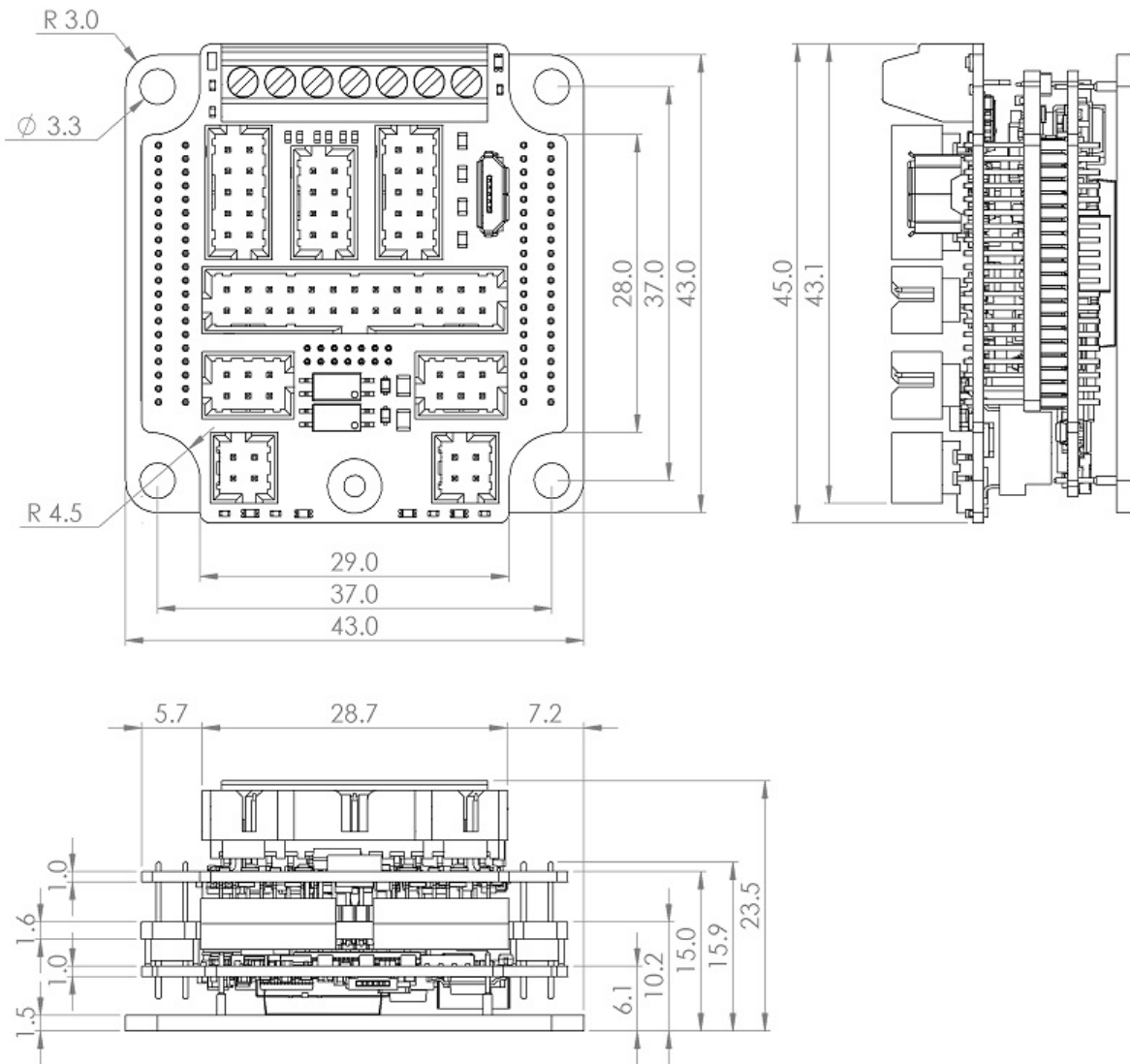

<sup>88</sup> <http://ingeniamc.com/support/triton>

 **3D Model**

For further detail, download the [STEP 3D model and PDF 3D](#)<sup>89</sup> for this variant. Note that the model is simplified: it does not show all the internal components, but does show the major volumes.

---

<sup>89</sup> <http://ingeniamc.com/support/triton>

## 9 Application Software

### 9.1 Configuration

To connect, configure, tune your motor or upgrade the firmware of the Triton Go, install Ingenia **Motion Lab**<sup>90</sup> suite. The software package includes USB drivers.



#### **Keep the firmware updated**

Before configuring your drive for a new application make sure you have upgraded to the latest firmware revision.



### 9.2 Applications

If you want to make your own application to communicate with the Triton Go and develop standalone or multiaxis systems you can use the multi-platform library **MCLIB**<sup>91</sup>.



### 9.3 Arduino

To start an Arduino based project easily, connect using the serial **RS485 port** (see page 23) of the Triton Go and use our Arduino Library **Ardulib**<sup>92</sup>.



---

<sup>90</sup> <http://ingeniamc.com/software#motionlab>

<sup>91</sup> <http://ingeniamc.com/software#mclib>

<sup>92</sup> <http://ingeniamc.com/software#ardulib>

## 10 Service

We are committed to quality customer service. In order to serve in the most effective way, please open a ticket on our service desk at [www.ingeniamc.com/support](http://www.ingeniamc.com/support) or contact your local sales representative for assistance.

If you are unaware of your local sales representative, please contact the Customer Support.

Spain	INGENIA HEADQUARTERS	<a href="http://www.ingeniamc.com">www.ingeniamc.com</a>	<a href="mailto:info@ingeniamc.com">info@ingeniamc.com</a>
France	A2V	<a href="http://www.a2v.fr">www.a2v.fr</a>	<a href="mailto:a2v@a2v.fr">a2v@a2v.fr</a>
Germany	MACCON GMBH	<a href="http://www.maccon.de">www.maccon.de</a>	<a href="mailto:info@maccon.de">info@maccon.de</a>
India	MPAGS	<a href="http://www.mapgs.com">www.mapgs.com</a>	<a href="mailto:info@mpags.com">info@mpags.com</a>
Israel	MEDITAL	<a href="http://www.medital.co.il">www.medital.co.il</a>	<a href="mailto:comotech@medital.co.il">comotech@medital.co.il</a>
Italy	SERVOTECNICA SPA	<a href="http://www.servotecnica.com">www.servotecnica.com</a>	<a href="mailto:info@servotecnica.com">info@servotecnica.com</a>
Norway	ELECTRO DRIVES AS	<a href="http://www.electro-drives.no">www.electro-drives.no</a>	<a href="mailto:firmapost@electro-drives.no">firmapost@electro-drives.no</a>
Portugal	MECÂNICA MORDERNA	<a href="http://www.mecmod.com/pt">www.mecmod.com/pt</a>	<a href="mailto:vendas@mecmod.com">vendas@mecmod.com</a>
Russia	AVI SOLUTIONS	<a href="http://www.avi-solutions.com">www.avi-solutions.com</a>	<a href="mailto:sales@avi-solutions.com">sales@avi-solutions.com</a>
Singapore	I-MOTION	<a href="http://www.imotionasia.com">www.imotionasia.com</a>	<a href="mailto:ivan@imotionasia.com">ivan@imotionasia.com</a>
South Korea	SERVOSTAR	<a href="http://www.servostar.co.kr">www.servostar.co.kr</a>	<a href="mailto:servo@servostar.co.kr">servo@servostar.co.kr</a>
South Korea	ALLTEK	<a href="http://www.alltek.co.kr">www.alltek.co.kr</a>	<a href="mailto:info@alltek.co.kr">info@alltek.co.kr</a>
Spain	MECANICA MORDERNA	<a href="http://www.mecmod.com/es">www.mecmod.com/es</a>	<a href="mailto:mecmod@mecmod.com">mecmod@mecmod.com</a>
Spain	GIZATECH	<a href="http://www.gizatech.eu/">www.gizatech.eu/</a>	<a href="mailto:comercial@milexia.es">comercial@milexia.es</a>
Switzerland	ANTRIMON MOTION AG	<a href="http://www.antrimon.com">www.antrimon.com</a>	<a href="mailto:motion@antrimon.com">motion@antrimon.com</a>
Turkey	FEMSAN	<a href="http://www.femsan.com">www.femsan.com</a>	<a href="mailto:melike@femsan.com">melike@femsan.com</a>
United Kingdom	MOTION CONTROL PRODUCTS	<a href="http://www.motioncontrolproducts.com">www.motioncontrolproducts.com</a>	<a href="mailto:info@motioncontrolproducts.com">info@motioncontrolproducts.com</a>
United States	NAMPRO	<a href="http://www.namproinc.com">www.namproinc.com</a>	<a href="mailto:sales@namproinc.com">sales@namproinc.com</a>
United States	GROUP SIX	<a href="http://www.grp6.com">www.grp6.com</a>	<a href="mailto:ingenia@grp6.com">ingenia@grp6.com</a>

INGENIA-CAT S.L.

8-14 MARIE CURIE, ADVANCED  
INDUSTRY PARK

08042 BARCELONA

**INGENIA**  
passion for motion